



Palladium 100V

VPA-060

VPA-150

VPA-250

ORDERCODE D4141

ORDERCODE D4142

ORDERCODE D4143



SHOWELECTRONICS FOR PROFESSIONALS

Congratulations!

You have bought a great, innovative product from DAP Audio.

The Dap Audio Palladium 100V Series brings excitement to any venue. Whether you want simple plug-&-play action or a sophisticated show, this product provides the effect you need.

You can rely on DAP Audio, for more excellent audio products.

We design and manufacture professional sound equipment for the entertainment industry.

New products are being launched regularly. We work hard to keep you, our customer, satisfied.

For more information: iwant@dap-audio.info

You can get some of the best quality, best priced products on the market from DAP Audio.

So next time, turn to DAP Audio for more great sound equipment.

Always get the best -- with DAP Audio !

Thank you!



Dap Audio

Dap Audio Palladium 100V Series™ Product Guide

Warning..... 2
 Safety-instructions..... 2
 Operating Determinations..... 3

Description..... 4
 Features Frontside..... 4
 Backside..... 4

Installation..... 5

Set Up and Operation..... 5

Connection Cables..... 8

Maintenance..... 9

Troubleshooting..... 9

Product Specifications..... 10

WARNING



**FOR YOUR OWN SAFETY, PLEASE READ THIS USER MANUAL CAREFULLY
BEFORE YOUR INITIAL START-UP!**

SAFETY INSTRUCTIONS

Every person involved with the installation, operation and maintenance of this device has to:

- be qualified
- follow the instructions of this manual



Before your initial start-up, please make sure that there is no damage caused by transportation. Should there be any, consult your dealer and do not use the device.

To maintain perfect condition and to ensure a safe operation, it is absolutely necessary for the user to follow the safety instructions and warning notes written in this manual.

Please consider that damages caused by manual modifications to the device are not subject to warranty.

This device contains no user-serviceable parts. Refer servicing to qualified technicians only.

IMPORTANT:

The manufacturer will not accept liability for any resulting damages caused by the non-observance of this manual or any unauthorized modification to the device.

- Never let the power-cord come into contact with other cables! Handle the power-cord and all connections with the mains with particular caution!
- Never remove warning or informative labels from the unit.
- Do not open the device and do not modify the device.
- Do not insert objects into air vents.
- Do not connect this device to a dimmerpack.
- Do not switch the device on and off in short intervals, as this would reduce the system's life.
- Only use device indoor, avoid contact with water or other liquids.
- Avoid flames and do not put close to flammable liquids or gases.
- Always disconnect power from the mains, when device is not used or before cleaning! Only handle the power-cord by the plug. Never pull out the plug by tugging the power-cord.
- Make sure that the available voltage is not higher than stated on the rear panel.
- Make sure that the power-cord is never crimped or damaged. Check the device and the power-cord from time to time.
- Never use anything to cover the ground contact.
- Make sure that there is sufficient room on all sides of the system for air circulation.
- Avoid ground loops! Always be sure to connect the power amps and the mixing console to the same electrical circuit to ensure the same phase!
- Please turn off the power switch, when changing the power cord or signal cable.

- Make sure that the amplifier is turned down, before turning the power on or off. So you can avoid supersonic frequencies, which could damage your speakers.
- Don't put your equipment next to TV, radio, etc., because of interference or distortion.
- If you connect other parts of the system, be careful of ground loops.
- The best way to avoid ground loops is connecting the electrical system ground to one central point ("star" system). In this case the mixer can act as a central point.
- To prevent humming, please try different combinations of ground-lift or connect all chassis to the system ground, either by a power cable or frontcover rack screws.
- Before changing the ground, always turn off your amplifier.
- Please read this manual carefully and keep it for future reference. Remember that the amplifier has a better value on the market, if you save the carton and all packing materials.
- Prevent distortion! Make sure that all components connected to the Palladium have sufficient power ratings. Otherwise distortion will be generated because the components are operated at their limits.
- Make sure you don't use the wrong kind of cables or defective cables.
- Make sure that signals into the mixer are balanced, otherwise hum could be created.
- If device is dropped or struck, disconnect mains power supply immediately. Have a qualified engineer inspect for safety before operating.
- If the device has been exposed to drastic temperature fluctuation (e.g. after transportation), do not switch it on immediately. The arising condensation water might damage your device. Leave the device switched off until it has reached room temperature.
- If your Dap Audio device fails to work properly, discontinue use immediately. Pack the unit securely (preferably in the original packing material), and return it to your Dap Audio dealer for service.
- Allow time to cool down, before cleaning or servicing.
- For replacement use fuses of same type and rating only.
- This device falls under protection class I. Therefore it is essential to connect the yellow/green conductor to earth.
- Repairs, servicing and electric connection must be carried out by a qualified technician.
- WARRANTY: Till one year after date of purchase.

OPERATING DETERMINATIONS

This device is not designed for permanent operation. Consistent operation breaks will ensure that the device will serve you for a long time without defects.

If this device is operated in any other way, than the one described in this manual, the product may suffer damages and the warranty becomes void.

Any other operation may lead to dangers like short-circuit, burns, electric shock, crash etc. You endanger your own safety and the safety of others!

Improper installation can cause serious damage to people and property !

Description of the device

Features

The Palladium 100V is a 100V amplifier from DAP Audio.
There are 3 different versions: VPA-060, VPA-150, VPA-250.

VPA-060
2x 60 Watt

VPA-150
2x 150 Watt

VPA-250
2x 250 Watt

Overview

Frontside

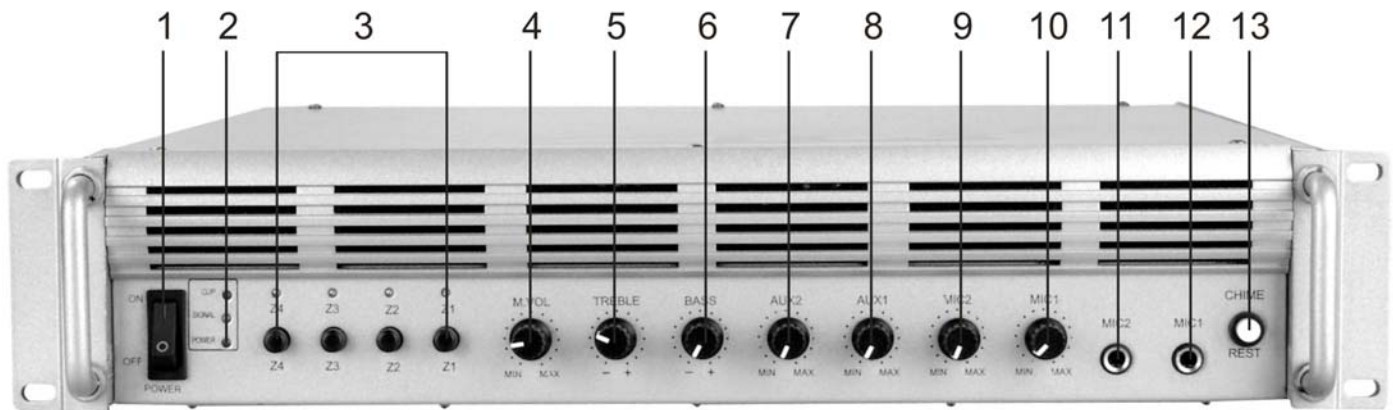

- | | |
|----------------------------------|-------------------------|
| 1) ON/OFF | 8) Aux 1 Control |
| 2) CLIP / SIGNAL / POWER LEDs | 9) Mic 2 Control |
| 3) Z1, Z2, Z3, Z4 Switches +LEDs | 10) Mic 1 Control |
| 4) M. Volume Control | 11) Mic 2 Input Jack |
| 5) Treble Control | 12) Mic 1 Input Jack |
| 6) Bass Control | 13) Chime / Rest Button |
| 7) Aux 2 Control | |

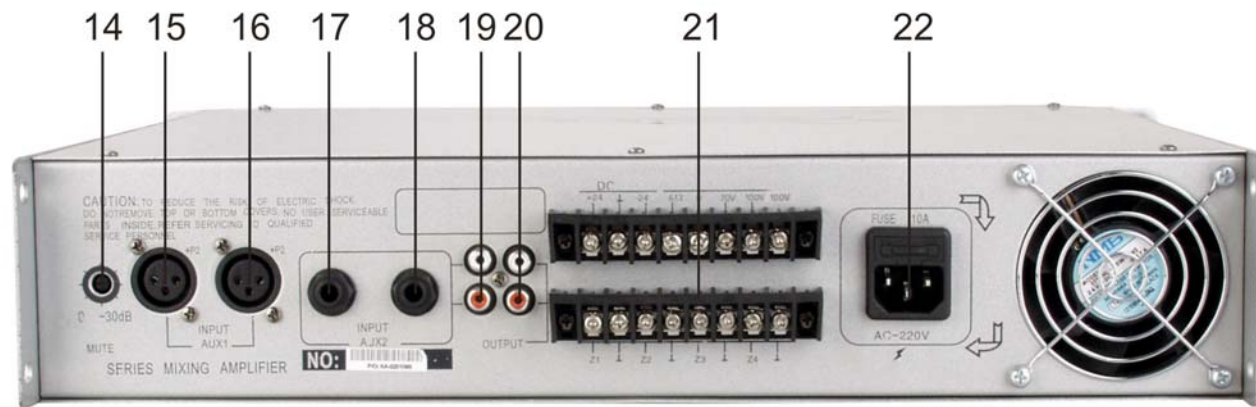

Backside

- | | |
|----------------------|---|
| 14) Mute (0/-30dB) | 19) Record Return L/R |
| 15) XLR Input Aux 1 | 20) Record Send L/R |
| 16) XLR Input Aux 1 | 21) Output terminals: connect to the speakers |
| 17) Aux 2 Input Jack | 22) IEC Connector + Fuse |
| 18) Aux 2 Input Jack | |

Installation

Palladium 100V Installation

Remove all packing materials. Check that all foam and plastic padding has been removed. Screw the equipment into a 19" rack. Connect all cables.

Always disconnect from electric mains power supply before cleaning or servicing. Damages caused by non-observance are not subject to warranty.

Set Up and Operation

Before plugging the unit in, always make sure that the power supply matches the product specification voltage. Do not attempt to operate a 120V specification product on 240V power, or vice versa. Do not supply power before all components of the system are set up and connected properly.

DC power or battery supply's connection

- The unit will also operate with 2 external 24V batteries or another source with positive and negative (-) voltage against ground. Power connection is made at the DC terminal strip on the rear panel.
- If the AC power supply fails, transfer to DC power is instantaneous, automatic and silent.
- The amplifier is not capable of recharging the connected battery. Thus, it is recommended to have a suitable device at hand. When the amplifier is on the DC power source, the nominal power handling capacity operated drops and will not reach full power capacity.

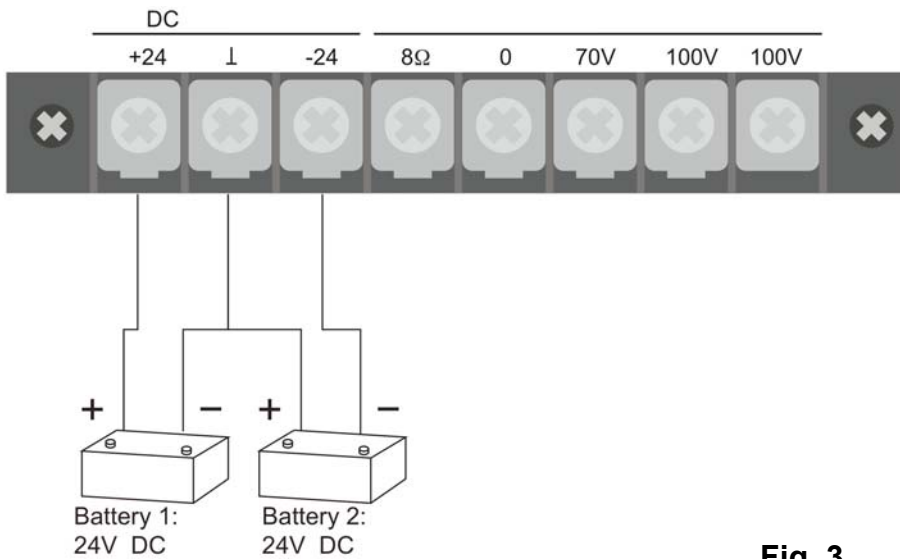

Fig. 3

Low Impedance Speaker Output: 8Ω

The low impedance 8Ω terminal is for connecting of a few large-output speakers, when constant-voltage speaker systems are unnecessary or the distance between the amplifier and the speakers is below 50m. The total speaker load impedance must be matched to the output impedance (8Ω) of the amplifier for the most efficient power-transfer.

Be sure that total impedance of speakers is above 8Ω however; do not raise the amplifier's output power above the allowable input power of the speaker. If the amplifier's output power should be raised above the maximum, the speakers could be damaged.

LOW IMPEDANCE OUTPUT

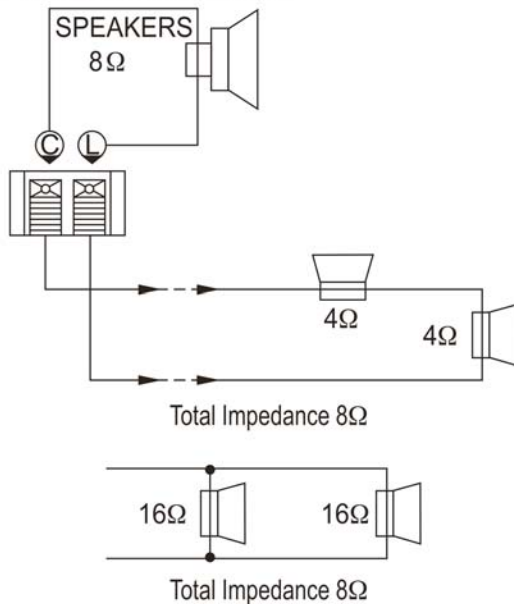

Fig. 4

Connection Input

The balanced phone jack inputs have a nominal impedance of 20 KΩ (10KΩ with unbalanced wiring) and will accept the line level output of most devices. The correct input depends on 2 factors: (1) whether the input signals are balanced or unbalanced, and (2) whether the signal source floats or has ground reference.

Connecting Power

The actual current draw, the amplifier demands from the AC mains, depends on many factors (its load, output level or the crest factor of its program material).

The power requirement is rated under typical music conditions, with both channels driven so those peaks are just at the clipping point.

Indicators

The Palladium features 3 front LED indicators per channel: Clip, Signal and Power. These LED indicators inform the user of each channel's operating status and warn of possible abnormal conditions.

Clip LED

A channel's red clip LED will light dimly at the onset of clipping and increase in brilliance, as clipping becomes more severe, staying on until the clipping ceases. If the LED is flashing quickly and intermittently, the channel is just at the clip threshold, while a steady, bright glow means the amp is fully clipped.

Reduce the gain to prevent severely clipped waveforms reaching the speakers.

Signal LED

This LED will light more intense if the input signal increases.

Power LED

This indicator LED lights, when the amplifier has been turned on, AC power is available and the low-voltage power supply and fan are operational

Protection Features

Every amplifier incorporates several circuits to protect themselves and the speakers under virtually any situation. Dap Audio has attempted to make the amplifier as “foolproof” as possible by making it impervious to short and open circuits, DC Voltage and overheating.

When a problem occurs, that causes a channel to go into a protection mode, the Power LED will dim. DC voltage on the output, excessive subsonic frequencies, or thermal overloads will cause the channel's output relay to disconnect the speaker load, until the problem is corrected or the amplifier cools down.

The internal fan will keep the amplifier operating well within its intended temperature range under all normal conditions.

When a channel's heat sink temperature reaches 90 °C, which may indicate an obstructed air supply, clogged air filter, etc, the channel will disconnect its load. Normal operation will resume automatically once it cools to 80 °C. During this time, the channel's Power LED will dim.

Short Circuit

If an output is shorted, the protection circuit will be more sensitive, than in the normal protection situation and will protect the channel's output transistors from the current stress. The channel's Power LED will dim. If the short circuit remains, the channel will eventually thermally protect itself by disconnecting the load.

DC Voltage Protection

If an amplifier channel detects DC voltage at its output, its output will immediately open to prevent speaker damage. The channel's Power LED will dim.

Subsonic Frequencies

All amplifiers have a built-in subsonic frequency protection circuit, cornered at 10Hz, for each channel. An additional feature is a special high frequency protection technology, which enables you to automatically disconnect speakers, when excessive high frequency energy appears at the output.

Turn-On/Turn-Off-Protection

At power up, the speakers are disconnected. The power supplies charge for about 2-3 seconds and stabilize, and then the speakers are connected. When power is removed, speaker loop is synchronized with the turn off signal, therefore no thumps or pops are heard.

Speaker-Protection

All amplifiers automatically protect speakers from DC voltage, subsonic signals and excessive high frequency signal, but users should be aware of the application limits of their speakers. Be aware that the amplifiers power does not exceed the speaker's power capabilities.

Connection Cables

Take care of the connector cables, always holding them by the connectors and avoiding knots and twists when coiling them: This gives the advantage of increasing their life and reliability, which is always to your advantage.

Periodically check that your cables are in good condition, that they are correctly wired and that all their contacts are perfectly efficient: a great number of problems (faulty contacts, ground hum, discharges, etc.) are caused entirely by using unsuitable or faulty cables.

Headphones

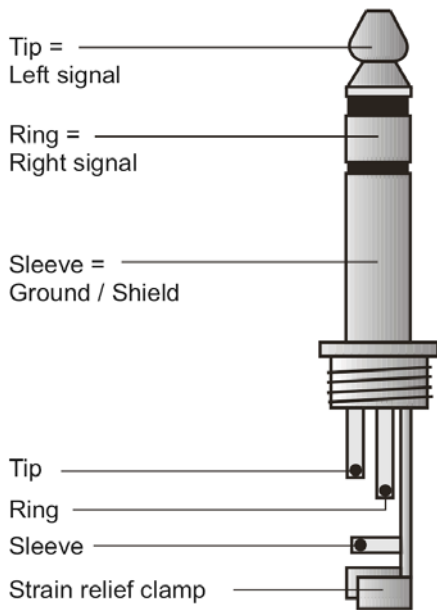

Unbalanced mono 1/4" jack plug

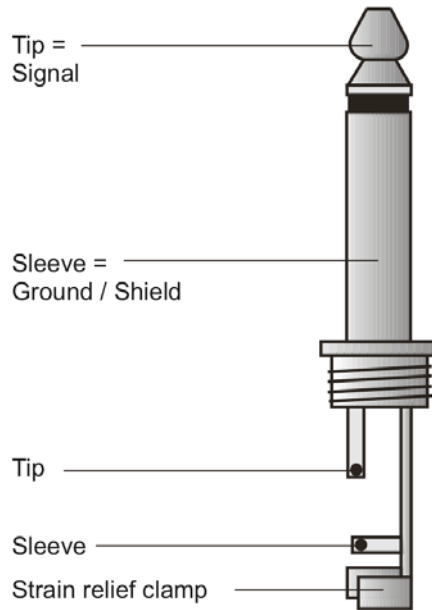

Balanced mono 1/4" jack plug

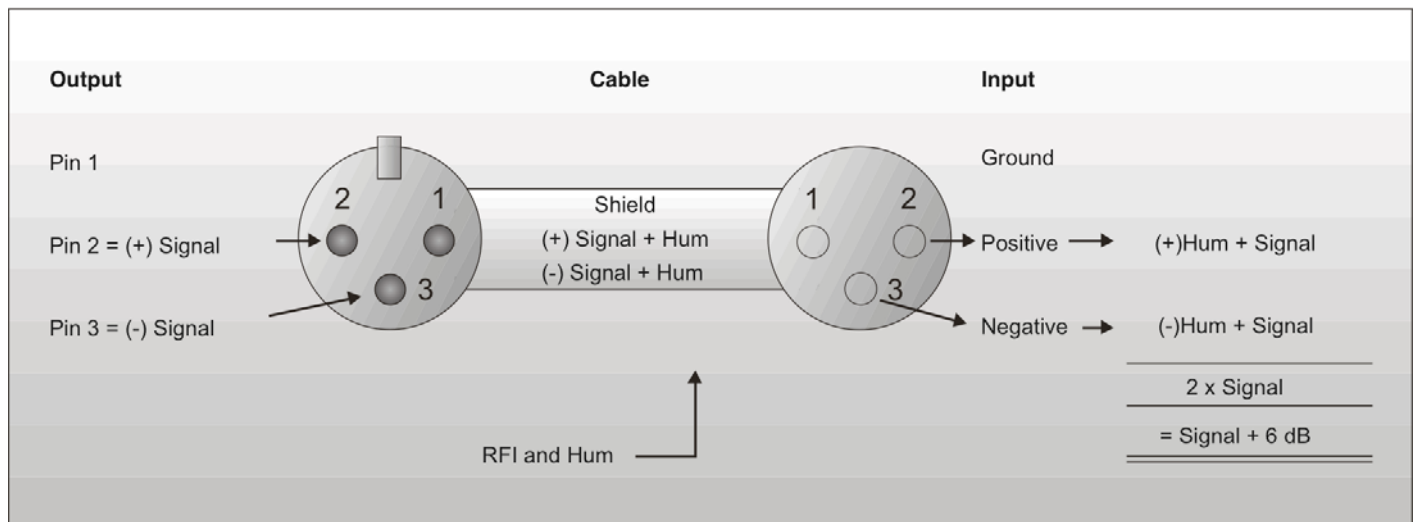
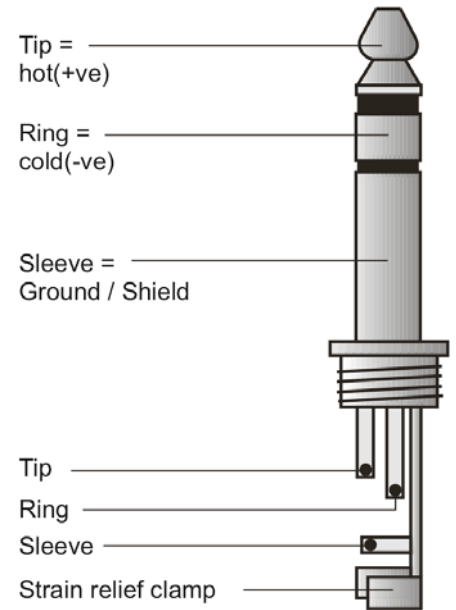

Compensation of interference with balanced connections

Balanced use with XLR connectors

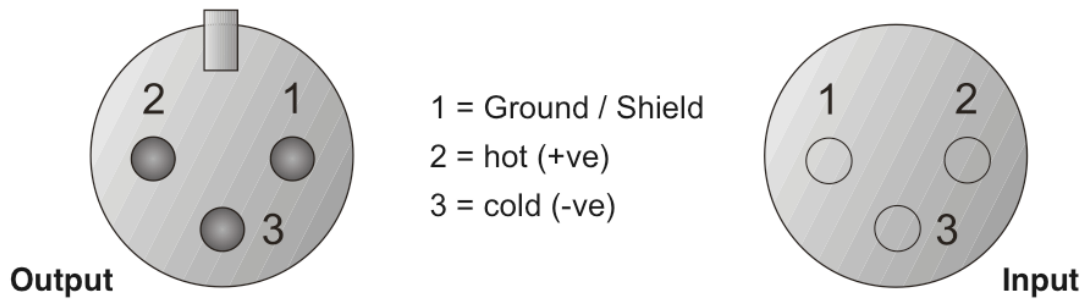

For unbalanced use PIN 1 and PIN 3 have to be bridged

Maintenance

The Dap Audio Palladium 100V Series requires almost no maintenance. However, you should keep the unit clean. Disconnect the mains power supply, and then wipe the cover with a damp cloth. Do not immerse in liquid. Do not use alcohol or solvents.

Keep connections clean. Disconnect electric power, and then wipe the audio connections with a damp cloth. Make sure connections are thoroughly dry before linking equipment or supplying electric power.

Troubleshooting

DAP Audio Palladium 100V Series

This troubleshooting guide is meant to help solve simple problems.

If a problem occurs, carry out the steps below in sequence until a solution is found. Once the unit operates properly, do not carry out following steps.

1. If you experience low output or no output at all, unplug the amplifier immediately.
2. Check power from the wall, all cables, the fuse, etc.
3. If all of the above appears to be O.K., plug the unit in again.
4. If nothing happens after 30 seconds, turn off the amplifier and unplug the device.
5. Return the machine to your DAP Audio dealer.

Product Specifications

Specification	VPA-060	VPA-150	VPA-250
Power (RMS)	60W	150W	250W
Frequency Response	100 Hz -16KHz		
Output Regulation	Less than 3dB, no load to full load		
Speaker Output	8 Ω, 70V, 100V		
Aux Ouput	600 Ω, 1V (0dB)		
Inputs	Mic 1, 2 / 600 Ω, 2,0 mV (-54dBV) Unbalanced Aux 1, 2 / 10 KΩ, 250 mV (-10dBV) Unbalanced		
Distortion	Less than 0,1% at 1Khz, 1/3 Power		
Input Impedance	20KΩ, balanced 10KΩ, unbalanced	20KΩ, balanced 10KΩ, unbalanced	20KΩ, balanced 10KΩ, unbalanced
Signal-to-Noise Ratio	Microphone 1, 2 66dB Aux 1, 2 70dB		
Tone	Bass +/- 10 dB at 100 Hz Treble +/- 10 dB at 10 Hz		
Muting function	Mic 1 overrides, other input signals with 0/-30dB attenuation		
Input Connectors	2 x XLR + 2 x Jack mounting socket		
Power Supply	230 V / 50 – 60 Hz		
Power Consumption	100W	200W	320W
Cooling	1 variable speed DC fans, front to rear		
Controls	Power switch, Master, Trebble, Bass, Aux 1+2, Mic 1+2 attenuators		
Indicators (per channel)	CLIP LED, Signal LED, Power LED		
Protection	AC Fuse, DC Voltage, Overload, Short cicuit		
Dimensions (LxWxH)	483x400x89 mm (19"x15"x3.4")		
Weight	16 Kg	20 Kg	24 Kg

Design and product specifications are subject to change without prior notice.





© 2005 DapAudio.