

# MIPRO<sup>®</sup>

## User Guide

### AD-707a

### UHF Wideband 4-Channel Antenna Divider



**MIPRO** MIPRO Electronics Co., Ltd.

Headquarters: 814 Pei-Kang Road, Chiayi, 60096, Taiwan.

Web: [www.mipro.com.tw](http://www.mipro.com.tw)

E-mail: [mipro@mipro.com.tw](mailto:mipro@mipro.com.tw)

CE FC



Design and specifications are subject to change without prior notice

AS110601

## ! IMPORTANT SAFETY INSTRUCTIONS !

1. Read these instructions.
2. Keep these instructions.
3. Heed all warnings.
4. Follow all instructions.
5. Do not use this apparatus near water.
6. Clean only with a dry cloth.
7. Do not block any ventilation openings. Install in accordance with the manufacturer's instructions.
8. Do not install near any heat sources such as radiators, heat registers, stoves, or other apparatus (including amplifiers) that produce heat.
9. Do not defeat the safety purpose of the polarised or ground plug: A polarised plug has two blades with one wider than the other. The wide blade is provided for your safety. When the provided plug does not fit into your outlet, consult an electrician for replacement of the obsolete outlet.
10. Protect the power cord from being walked on or pinched particularly at plug, convenience receptacles, and the point where they exit from the apparatus.
11. Only use attachments/accessories specified by the manufacturer.
12. Use only with a cart, stand, tripod, bracket, or table specified by the manufacturer, or sold with the apparatus. When a cart is used, use caution when moving the cart/apparatus combination to avoid injury from tip-over.
13. Unplug this apparatus during lightning storms or when unused for long periods of time.
14. Refer all servicing to qualified service personnel. Servicing is required when the apparatus has been damaged in any way, such as power-supply cord or plug is damaged, liquid has been spilled or objects have fallen into the apparatus, the apparatus has been exposed to rain or moisture, does not operate normally, or has been dropped.
15. To reduce the risk of fire or electric shock, do not expose this apparatus to rain or moisture.
16. Apparatus should not be exposed to dripping or splashing and no objects filled with liquids, should be placed on the apparatus.
17. Use only with the battery which specified by manufacturer.
18. The power supply cord set is to be the main disconnected device.



## WARNING

1. **FOR OUTDOOR USE:**  
To reduce the risk of fire or electric shock, do not expose this apparatus to rain or moisture.
2. **UNDER WET LOCATION:**  
Apparatus should not be exposed to dripping or splashing and no objects filled with liquids, such as vases should be placed on the apparatus.
3. **SERVICE INSTRUCTIONS:**  
CAUTION - These servicing instructions are for use by qualified service personnel only. To reduce the risk of electric shock, do not perform any servicing other than that contained in the operating instructions unless you are qualified to do so.



 This symbol indicates that dangerous voltage constituting a risk of electric shock is present within this unit.

 This symbol indicates that there are important operating and maintenance instructions in the literature accompanying this unit.

## FC & IC - ID

THIS DEVICE COMPLIES WITH PART 15 OF THE FCC RULES AND RSS-123 ISSUE2 OF CANADA. OPERATION IS SUBJECT TO THE FOLLOWING TWO CONDITIONS:

- (1) This device may not cause interference.
- (2) This device must accept any interference, including interference that may cause undesired operation of the device. This equipment complies with FCC RF radiation exposure limits set forth for an uncontrolled environment.

## Disposal

Dispose of any unusable devices or batteries responsibly and in accordance with any applicable regulations.



Disposing of used batteries with domestic waste is to be avoided!

Batteries / NiCad cells often contain heavy metals such as cadmium (Cd), mercury (Hg) and lead (Pb) that makes them unsuitable for disposal with domestic waste. You may return spent batteries/accumulators free of charge to recycling centres or anywhere else batteries/accumulators are sold.

2005-08-13

By doing so, you contribute to the conservation of our environment!

**Contents**

- 1 Key Features and Benefits
- 2 Part Names and Functions
- 3 Installation (2 Applications)
- 5 Cautions

**Key Features and Benefits**

1. Optimized for 470~800MHz carrier frequency range, which is fully compatible with US and EU telecom regulations.
2. Provided for 2~4 sets of UHF diversity receivers to operate from just a pair of antennas, greatly simplifying antenna installations and increasing reception distance and efficiency.
3. Adopts the latest high dynamic range and low noise component, advanced circuit design featuring very low inter-modulation distortion and eliminates the spurious interference in multiple system usage. System output gain approximately equals to 1.
4. 2 sets of antenna input/output connectors and 2 sets of 4-channel antenna output connectors for directly connecting to 4 sets of diversity receivers. The antenna input connector can be fitted with whip antenna or coaxial antenna of appropriate frequency band. Besides, through optional booster, it also can be linked to ground plane antenna or UHF wideband log antenna.
5. The output connector can be linked to the input connector of another antenna divider.
6. The input connector can provide bias for the ground plane antenna with optional antenna booster and the wideband receiving log antenna with built-in booster.
7. Power indicator of booster to detect the linkage of booster.
8. Dimensions (W × H × D) : 482 × 44 × 190 mm
9. Weight : Approx. 1.5 kg (3.3 lbs)

**The included accessories:**

- ① RG-58AU signal cable 40 cm (TNC) X 8 pieces
- ② Rack Mount Bracket X 1 pair
- ③ 12V/500mA power adapter X 1 piece
- ④ User Guide X 1 piece

### Part Names and Functions

#### Front Panel:

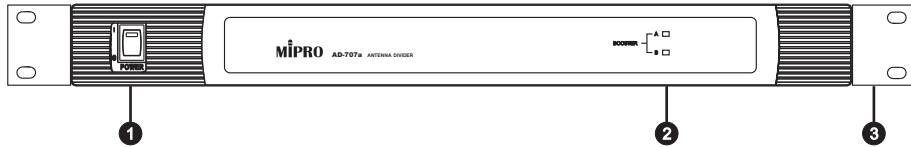

(Figure 1)

- ❶ **Power On/Off Switch:** When power is on, the light illuminates.
- ❷ **Booster Power Indicator:** The light illuminates when remote antenna booster is connected and successfully powered from antenna-in connector ❹ .
- ❸ **Rack Mount Bracket:** For mounting on an EIA standard 19" rack-mount cabinet.

#### Rear Panel:

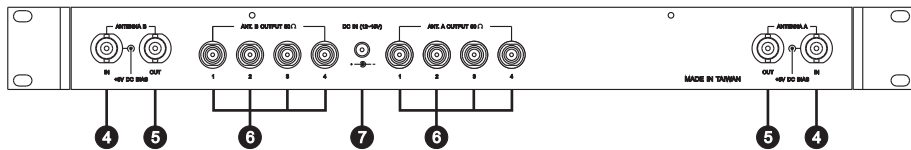

(Figure 2)

- ❹ **Antenna-in Connector:** Connects directly to an antenna or a booster with remote antenna. Connector provides regulated 8.3 V DC power for booster.
- ❺ **Antenna-out Connector:** Deliver pre-distributed signal so it can conveniently connect to another antenna divider.
- ❻ **Antenna Distribution Output Connector:** The distributed signal outputs for multiple systems.
- ❼ **DC Power Input Jack:** To connect DC 12V from an AC/DC adapter.

### Installation (2 Applications)

#### First Application:

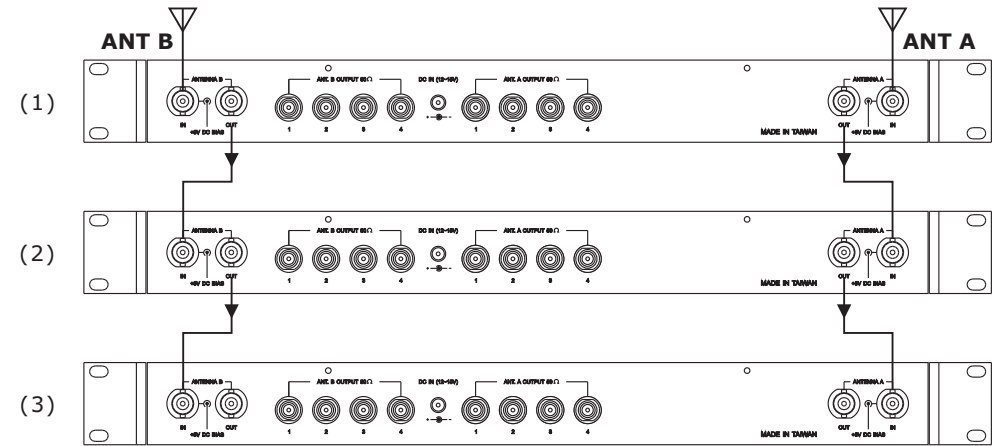

(Figure 3)

To build a larger divider system, when antenna-in connector of system (1) is connected to an antenna, system (1) can distribute signal to system (2) via antenna-out connector, and vice versa.

**Second Application:**

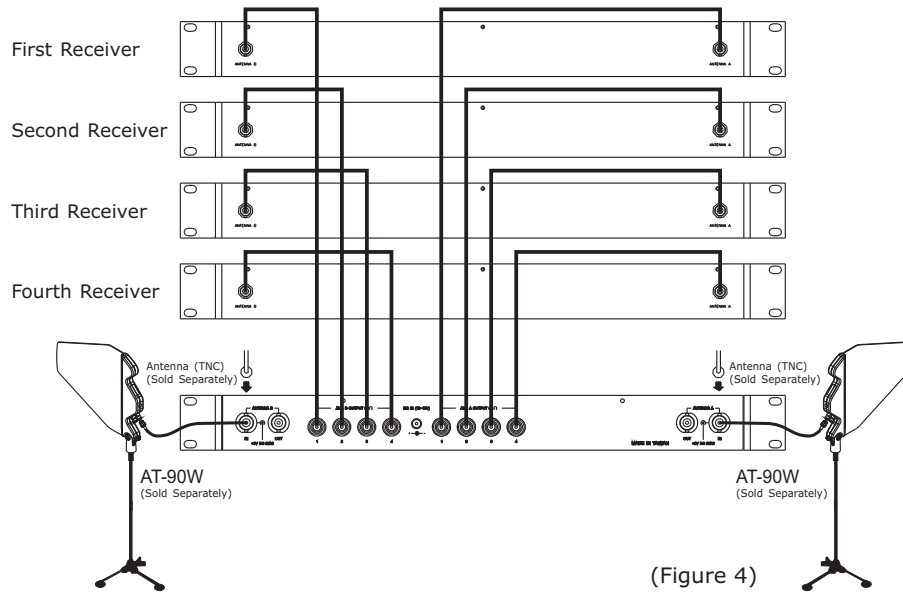

(Figure 4)

1. Use rack mount brackets ③ and install this system with receivers on an EIA standard cabinet.
2. Use receiver antennas or AT-90W's and install onto antenna-in connectors ④ . See Figure 4. MIPRO accessory, FB-30, front antenna mount brackets (not included); can also be installed at the front of the receiver to improve antenna reception.
3. Connect antenna distribution output connector ⑥ to antenna connector of each receiver via RG-58AU signal cable (included in the package).
4. Connect DC lead into the DC socket ⑦ , and the AC adapter into an AC outlet socket (Caution: adapter voltage must adhere to each local AC voltage range)
5. To operate, simply power-on the power switch.

**Cautions**

1. Antenna-in connector ④ has 8.3V DC output. Be cautious that any parts of antenna or core wire of antenna cable should not make direct contact with case to avoid electric shortage.
2. It will not function properly if DC voltage falls below 12V. However, if it exceeds 15V, it will damage internal circuit components.
3. Use 50Ω coaxial cables between receiver and divider. Best to keep cable length as short as possible. It is recommended to use the included cables.
4. When using antenna cables and remote antenna, please use 50Ω coaxial cables. The longer the cable or the smaller the cable diameter, the more loss of RF signals. Hence, please keep cable length under 6 meters. If longer antenna cable is needed, use larger diameter cable to reduce the loss of signal through the attenuation in the cabling.
5. This device is a wideband antenna divider (regulated at 480~800 MHz for EU). When pair this system with conventional narrowband 1/4 λ or coaxial antenna, please make sure frequency band of antenna matches with receiver.

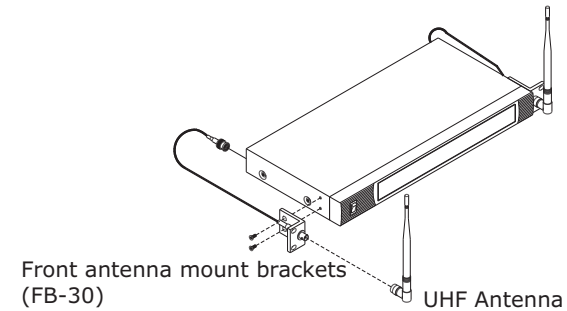

(Figure 5)