

Bose® FreeSpace® 3 Series II Loudspeaker

Installation Guide*

Installationsvejledning*

Installationsanleitung*

Guía de instalación*

Guide d'installation*

Guida all'installazione*

Installatiehandleiding*

Installationsanvisning*

The Bose logo, consisting of the word "BOSE" in a bold, italicized, sans-serif font, with a registered trademark symbol (®) to the upper right.

*For use by trained installers only

*Kun til brug for erfarne installatører

*Montage ausschließlich durch
ausgebildetes Installationspersonal

*Para uso exclusivo de instaladores capacitados

*Réservé aux installateurs ayant suivi une formation

*Solo per l'uso da parte di installatori professionisti

*Uitsluitend voor gebruik door ervaren installateurs

*Ska endast användas av utbildade installatörer



DECLARATION OF CONFORMITY

We, the offerer:

Bose® Corporation, The Mountain, Framingham, MA 01701-9168 USA
acknowledge our sole responsibility, that the product:

Kind of equipment: Loudspeaker
Type designation: FreeSpace® 3 Series II Acoustimass®
module

In accordance with EMC Directive 89/336/EEC and Article 10(1) of the Directive,
is in compliance with the following norm(s) or document(s):

Technical regulations: EN50081-1, EN50082-1

Accredited by:

Bose Corporation, The Mountain, Framingham, MA 01701-9168 USA

15 April 2002

Bose Products B.V.
Nijverheidstraat 8, 1135 GE Edam
The Netherlands

Nic Merks
Vice President Europe
Manufacturer's authorized EU representative

U.S. Regulatory information

The Bose FreeSpace 3 Series II Acoustimass® module and flush-mount satellite have been certified as General Purpose Loudspeakers, in accordance with UL1480.

The Bose FreeSpace 3 Series II Acoustimass Module and Flush-Mount Satellite also comply with the requirements of NFPA 70, National Electric Code 2002, Article 300-22(c) and UL2043 for use in air handling spaces, and NFPA 90A-1996 Installation of Air Conditioning and Ventilation Systems, Section 2-3.10.1(a), exception 3 when used with the PC-FreeSpace 3B and PC-FreeSpace 3F Plenum Cover Accessories.

Package contents

Kassen indeholder

Packungsinhalt

El paquete contiene

Contenu de l'emballage

Contenuto della confezione

Inhoud van de verpakking

Paketets innehåll

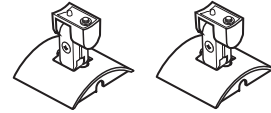
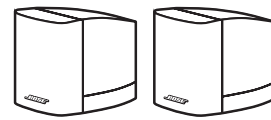
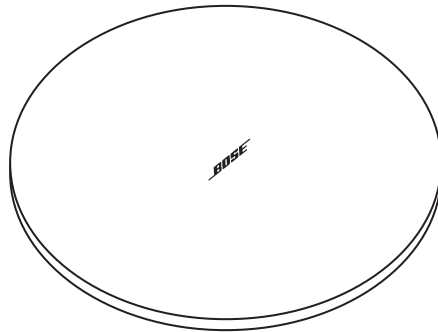
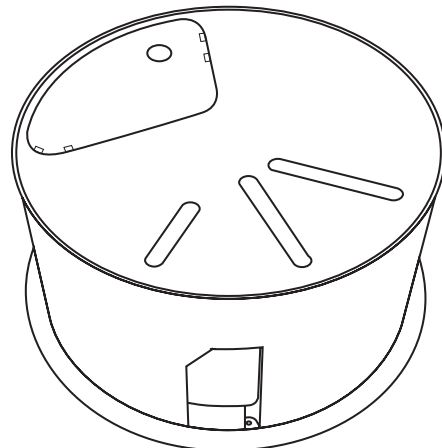

or
eller
oder
o

ou
o
of
eller

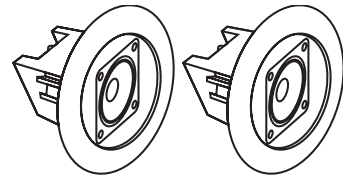

Dimensions

Mål

Abmessungen

Dimensiones

Dimensions

Dimensioni

Afmetingen

Dimensioner

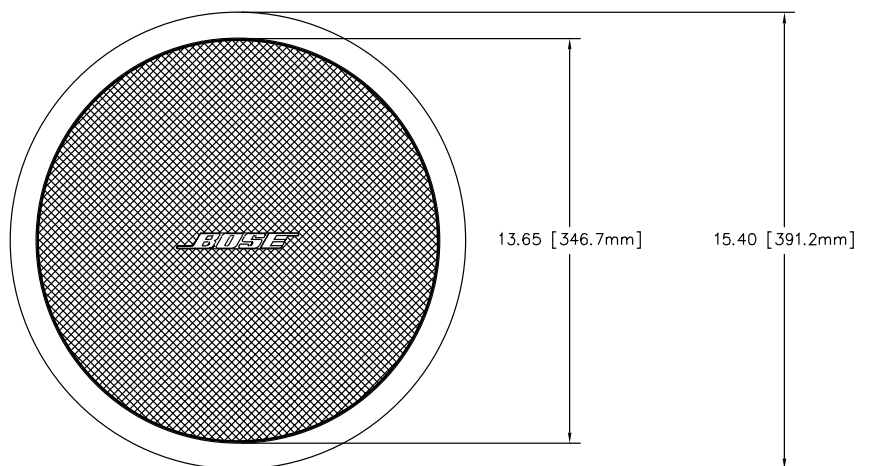

Front

Dimensions

Mål

Abmessungen

Dimensiones

Dimensions

Dimensioni

Afmetingen

Dimensioner

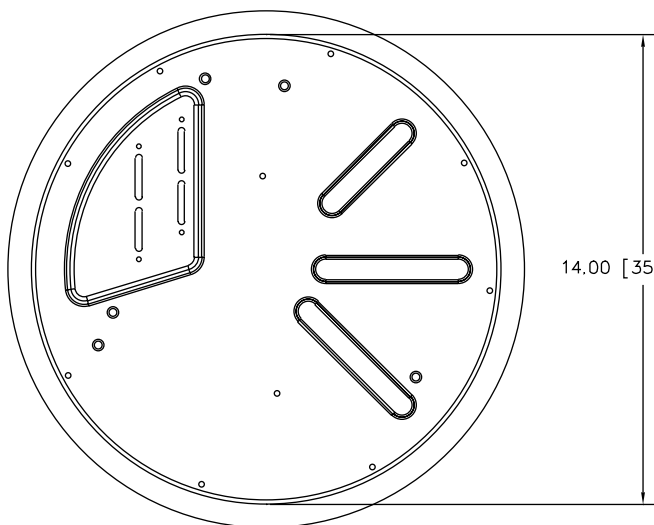

Rear

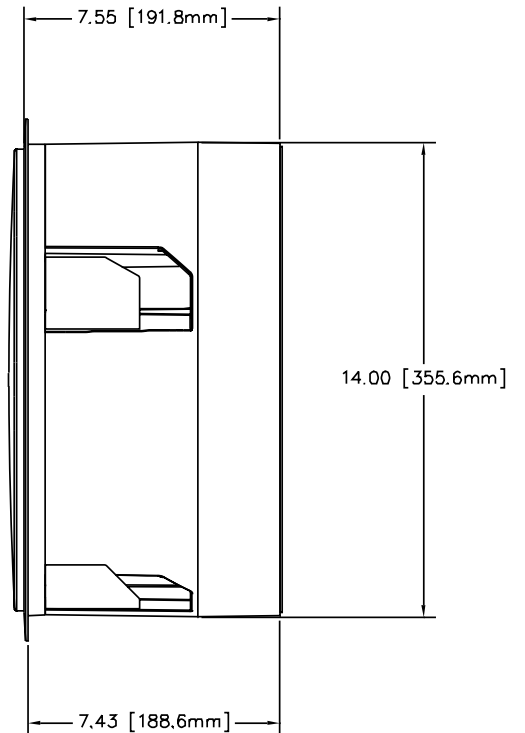

Side

**Dimensions
Mål
Abmessungen
Dimensiones
Dimensions
Dimensioni
Afmetingen
Dimensioner**

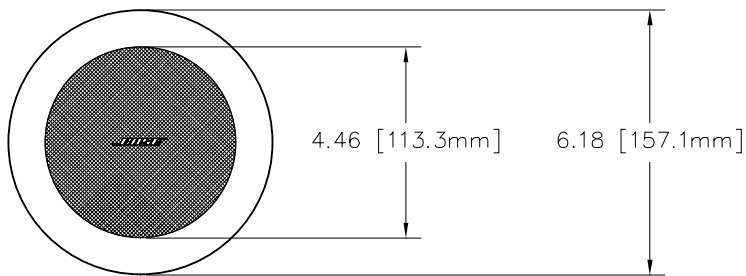
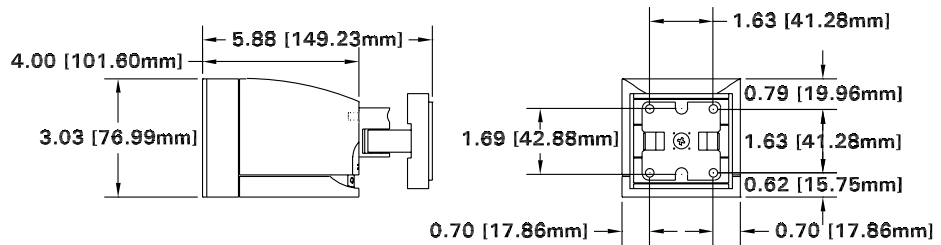
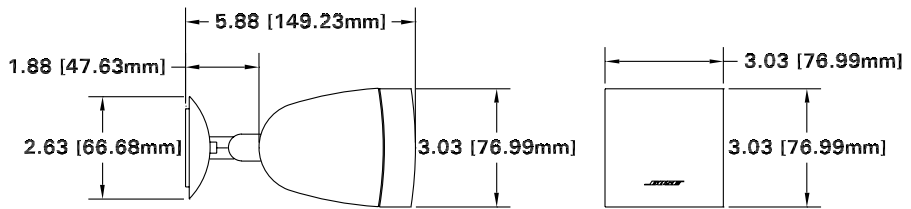

Front

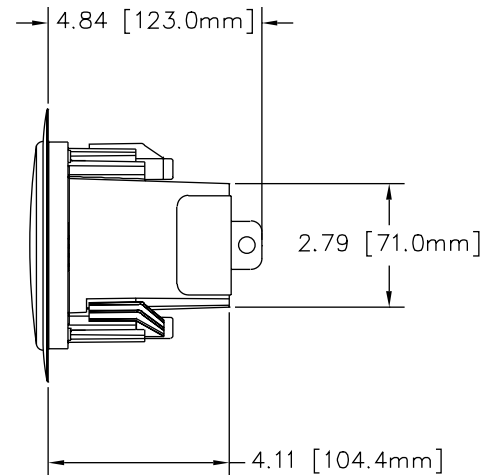

Side

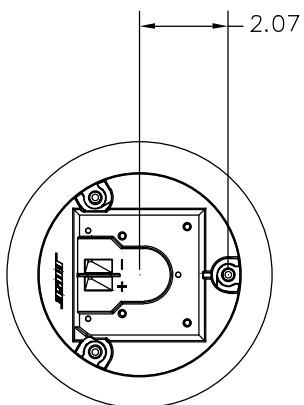

Rear

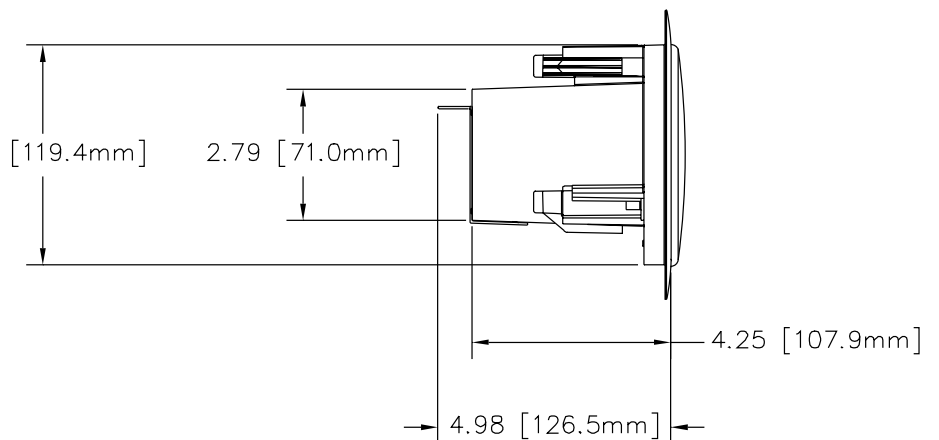

Side

Choices
Valgmuligheder
Optionen
Opciones
Au choix
Opzioni
Keuzes
Alternativ

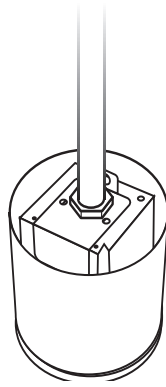

Bose® FreeSpace® 3F Cosmetic Cover

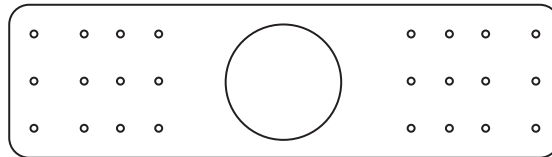
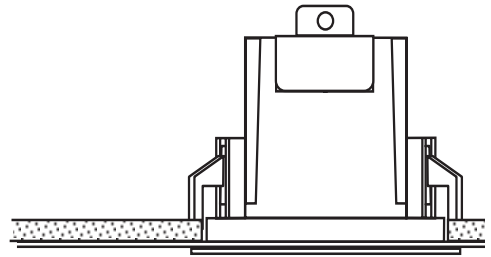

Bose FreeSpace 3F Rough-in Pan

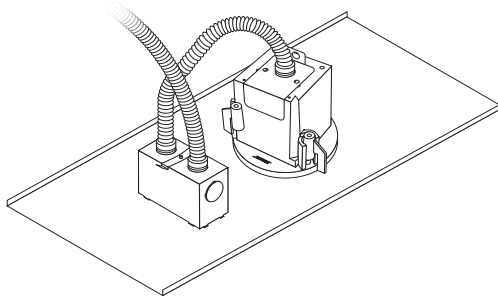

Bose 8/32 Junction Box

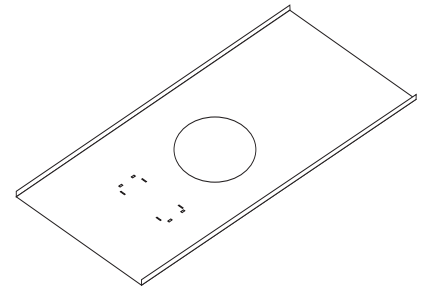

Bose FreeSpace® 3F Tile Bridge

PC-FreeSpace 3F Plenum Cover

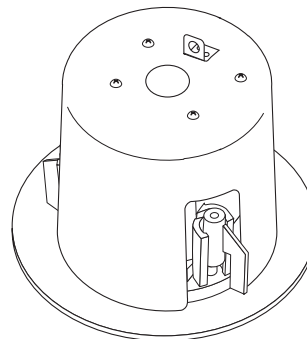

Installation/Instalación/Installazione/Installatie

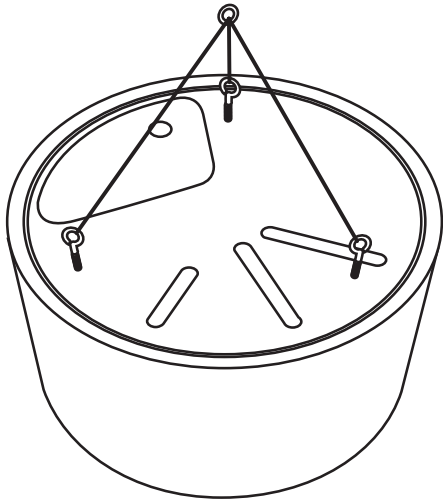

Bose® FreeSpace 3B Pendant Mount Kit

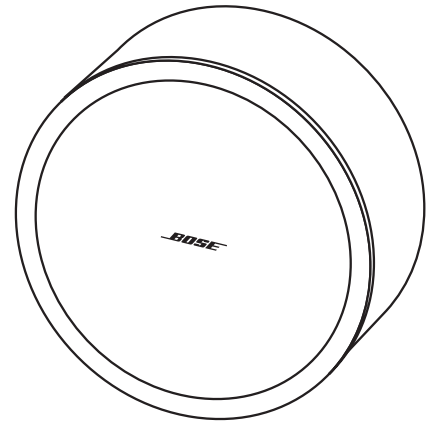

Bose FreeSpace 3B Surface Mount Kit

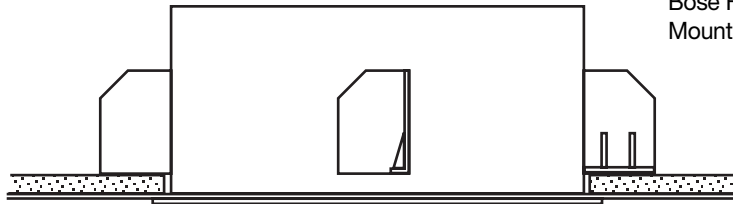

+

Required	Nécessite
Påkræves	È necessario
Erforderlich	Verplicht
Se requiere	Krävs

Bose FreeSpace 3B Rough-in Pan

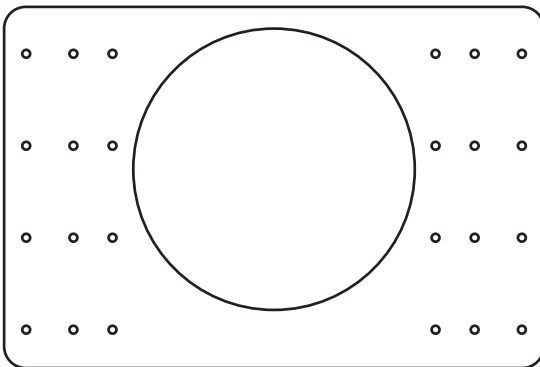

or
 eller
 oder
 o
 ou
 o
 of
 eller

Bose FreeSpace 3B
 Tile Bridge

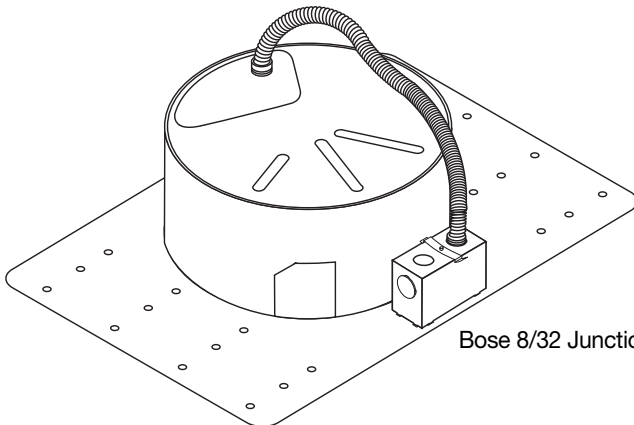
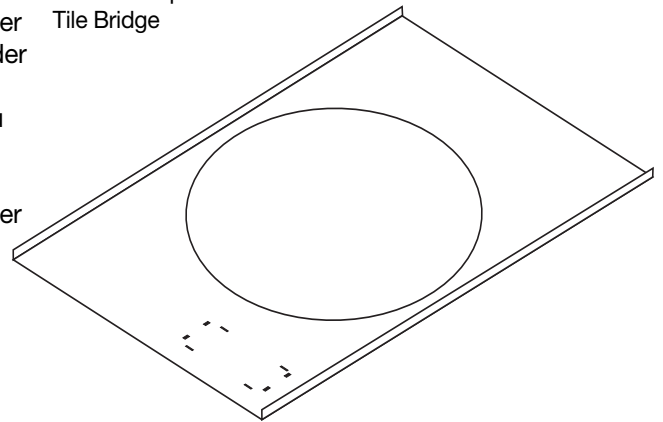

Bose 8/32 Junction Box

PC-FreeSpace 3B Plenum Cover

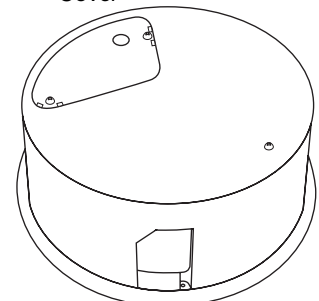

Amplifier output connection

Tilslutning til forstærkerudgang

Anschluss des Verstärkerausgangs

Conexión de salida del amplificador

Raccordement aux sorties de l'amplificateur

Connessione di uscita dell'amplificatore

Uitgangsverbinding van de versterker

Anslutning från förstärkare

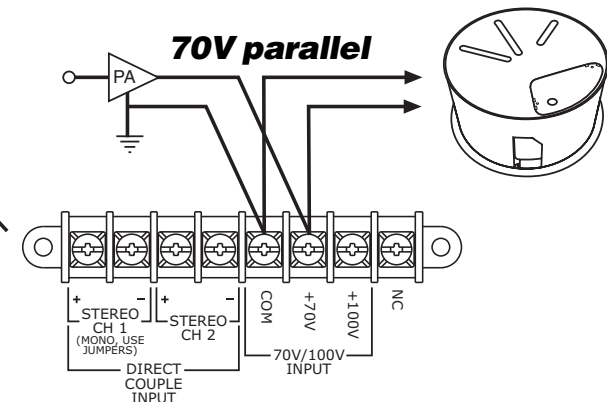
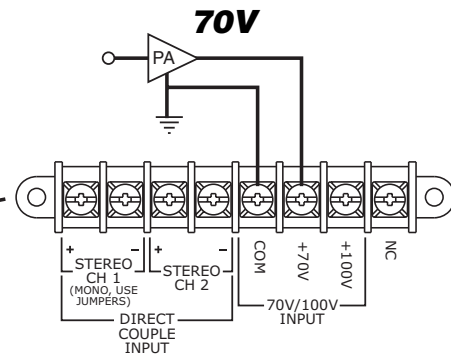
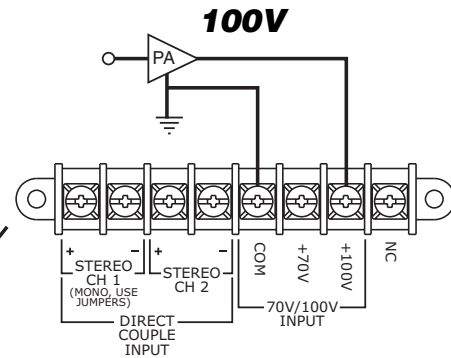
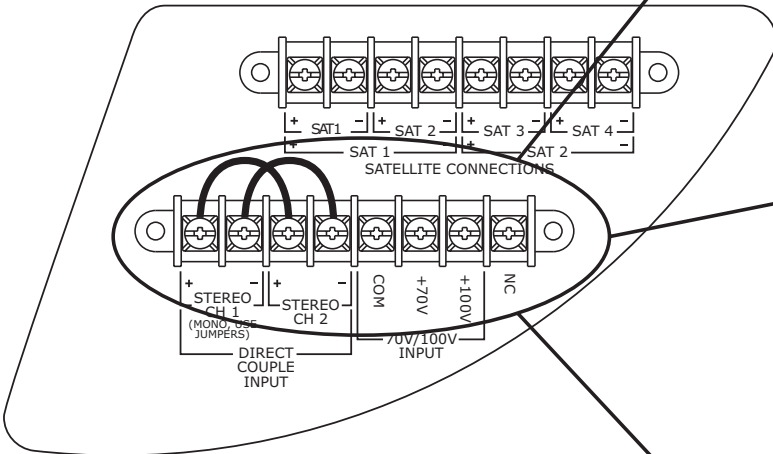
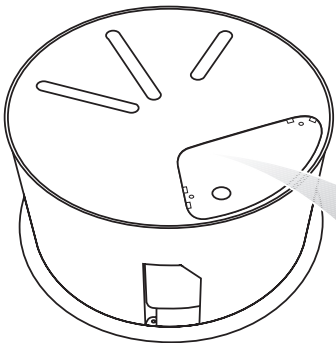

Transformer tap setting

Transformer tapsætning

Einstellen der Transformator-abgriffe

Ajuste del cambiador de la relación de transformación

Position des réglages du transformateur

Trasformatore: impostazione delle potenze intermedie

Aftakingsinstelling van de transformator

Tappinställning för transformator

- **Lower Wattage:** The transformer tap is set at the factory for 200W use. To set it for lower wattage, remove the end of the + jumper wire that is connected to 200W and reattach it to the appropriate tap (100W, 50W, or 25W).
- **Lavere watt:** Transformer tapsætningen indstilles på fabrikken til anvendelse ved 200 W. Hvis den skal indstilles til lavere watt, skal enden af kablet mærket+, der er sluttet til 200 W, flyttes til den passende omskifter (100 W, 50 W, eller 25 W).
- **Niedrige Wattzahl:** Der Transformatorabgriff ist ab Werk für 200W eingestellt. Wenn Sie eine niedrigere Wattzahl benötigen, entfernen Sie das Ende des +Verteilerdrahts vom 200W Abgriff und befestigen es am gewünschten Abgriff (100W, 50W bzw. 25W).
- **Vatíaje más bajo:** La relación de transformación viene establecida de fábrica para el uso de 200 W. Para cambiar a un vatíaje más bajo, retire el extremo del hilo de puente+ que está conectado a 200 W y vuelva a acoplarlo a la relación de transformación apropiada (100 W, 50 W o 25 W).
- **Puissance plus faible :** le réglage du transformateur est effectué en usine pour une puissance de 200 W. Si l'on souhaite utiliser une puissance plus faible, retirer l'extrémité du strap + raccordé sur la borne 200 W et replacer celui-ci sur la borne appropriée (100, 50, ou 25 W).
- **Potenze intermedie:** il trasformatore è impostato in fabbrica sulla potenza di 200 W. Per impostare una potenza inferiore, rimuovere l'estremità del ponticello + inserirla nel connettore da 200 W e inserirla nel connettore della potenza desiderata (100, 50 o 25 W).
- **Lager wattage:** De transformatoraftakking is in de fabriek ingesteld op 200 W. Om een lager wattage in te stellen verwijderd u het uiteinde van de + overbruggingsdraad die aangesloten is op de 200 W aansluiting en bevestigt u deze op de juiste aftakking (100 W, 50 W of 25 W).
- **Lägre watt:** Transformatorappen är inställd på fabriken för 200W. För lägre wattal, avlägsna änden av + bygeltråden som är ansluten till 200W och anslut den till lämplig tapp (100W, 50W eller 25W).

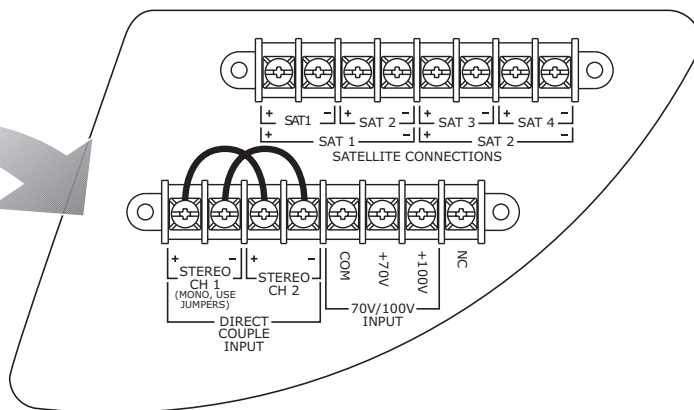
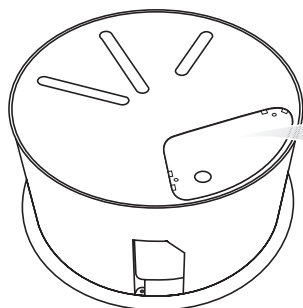
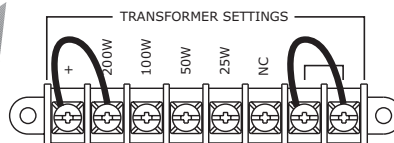
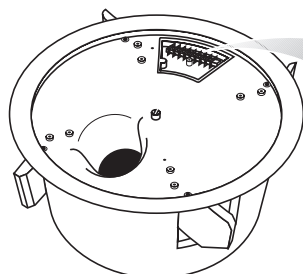

**Direct
(transformer
bypass) use**
**Direkte
(transformer
bypass) lavohms**
**Direkt-
Auslegung
(Umgehung des
Transformators)**
**Use directo
(desviación del
transformador)**
**Utilisation
directe
(transformateur
shunter)**
**Collegamento
diretto
(esclusione del
trasformatore)**
**Direct
(transformator
bypass) gebruik**
**Direkt
(transformator
-avledning)
användning**

- **Mono Direct:** To bypass the transformer and prepare the loudspeaker for 4Ω use and mono sound input, remove the two jumpers from the transformer settings on the front of the loudspeakers. Leave the CH1 and CH2 input jumpers on the back of the loudspeaker as they are.
- **Mono direkte:** Fjern de to jumpere fra transformerindstillingerne på forsiden af højttalerne for at foretage bypass af transformeren og forberede højttalerne til anvendelse ved 4 Ω og mono lydindgang. Lad CH1 og CH2 koblingskablerne sidde på bagsiden af højttalerne som de er.
- **Mono-Direkt:** Wenn Sie den Transformator umgehen möchten und den Lautsprecher für 4Ω und Mono-Soundeingang vorbereiten möchten, entfernen Sie die beiden Transformatorverteilerdrähte auf der Vorderseite der Lautsprecher. Die Verteilerdrähte für CH1- und CH2-Eingang auf der Rückseite der Lautsprecher bleiben unverändert.
- **Mono Directo:** Para desviar (bypass) el transformador y preparar el altavoz para uso de 4Ω y entrada de sonido en mono, retire únicamente los dos hilos de puente del transformador en la parte frontal de los altavoces. Deje los puentes de entrada CH1 y CH2 en la parte trasera del altavoz tal y como están.
- **Mode mono direct :** si l'on souhaite shunter le transformateur et préparer l'enceinte pour une utilisation 4 Ω en mode mono, retirer les 2 straps du système de réglage du transformateur situé à l'avant des enceintes. Laisser cependant les straps d'entrée CH1 et CH2, présents à l'arrière de l'enceinte, dans leur position initiale.
- **Mono, diretto:** per escludere il trasformatore e utilizzare l'altoparlante in configurazione 4Ω ingresso mono, rimuovere i due ponticelli del trasformatore sulla parte frontale degli altoparlanti. Non toccare i ponticelli di ingresso CH1 e CH2 sul retro dell'altoparlante.
- **Mono direct:** Om de transformator over te slaan en de luidspreker voor te bereiden op gebruik van 4Ω en mono verwijderd u alleen de twee overbruggingsdraden van de transformatorinstellingen voorop de luidsprekers. Laat de overbruggingsdraden van CH1 en CH2 achterop de luidspreker zoals ze zijn.
- **Monodirekt:** Gå förbi transformatorn och förbered högtalaren för 4Ω-användning och monoljud genom att avlägsna de två bygeltrådarna för transformatorn på högtalarnas framsida. Låt ingångstrådarna CH1 och CH2 sitta kvar på högtalarens baksida.

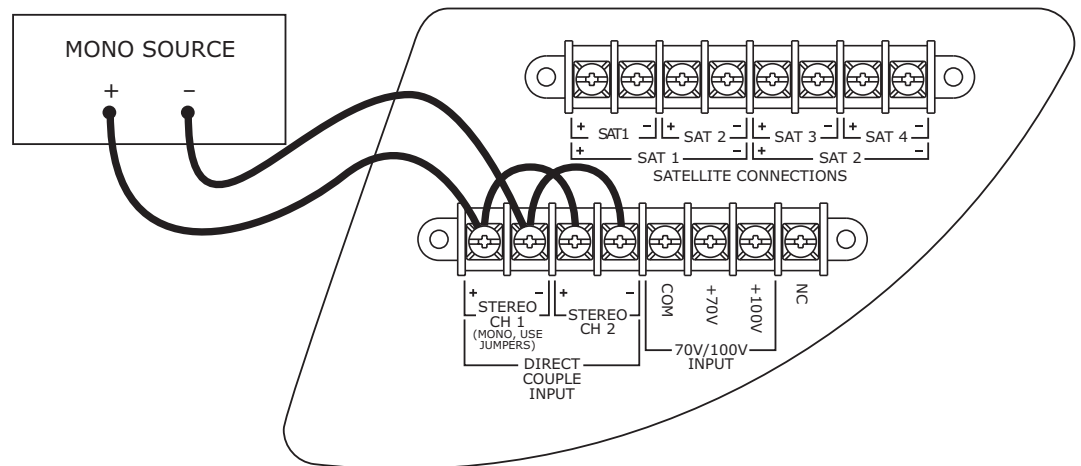

Installation/Instalación/Installazione/Installatie

- **Stereo Direct:** To bypass the transformer and prepare the loudspeaker for 6Ω use and stereo sound input, remove all jumper wires.
- **Stereo direkte:** Fjern alle koblingskabler ved benyttelse af lavohm på transformeren og forberedelse af højtaleren til anvendelse med 6 Ω og stereo lydindgang.
- **Stereo-Direkt:** Wenn Sie den Transformator umgehen möchten und den Lautsprecher für 6Ω und Stereo-Soundeingang vorbereiten möchten, entfernen Sie alle Verteilerdrähte.
- **Estéreo Directo:** Para desviar (bypass) el transformador y preparar el altavoz para uso de 6Ω y entrada de sonido en estéreo, retire los dos hilos de puente.
- **Mode stéréo direct :** si l'on souhaite shunter le transformateur et préparer l'enceinte pour une utilisation 6 Ω en mode stéréo, retirer tous les straps.
- **Stereo, diretto:** per escludere il trasformatore e utilizzare l'altoparlante in configurazione 6Ω ingresso stereo, rimuovere tutti i ponticelli.
- **Stereo direct:** Om de transformator over te slaan en de luidspreker voor te bereiden op gebruik van 6Ω en stereo verwijdert u alle overbruggingsdraden.
- **Stereodirekt:** Gå förbi transformatorn och förbered högtalaren för 6Ω-användning och stereoljud genom att avlägsna alla bygeltrådar.

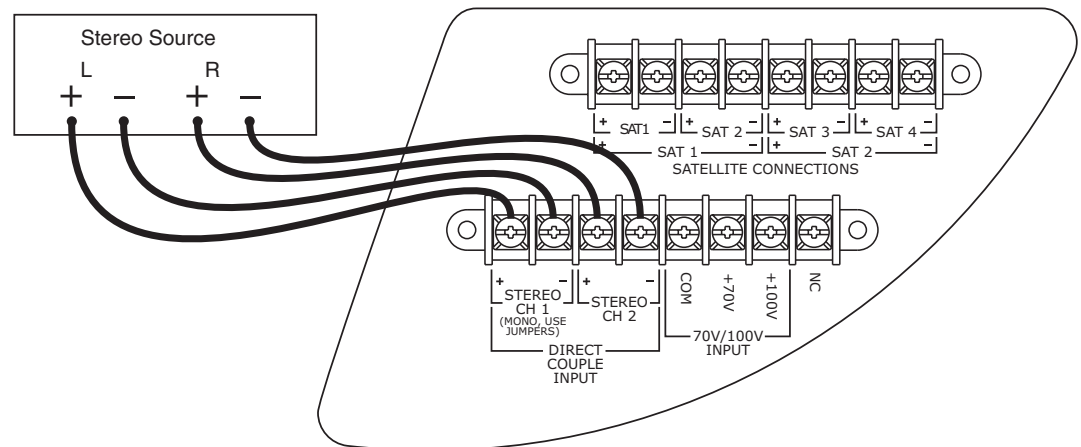

Satellite speaker connection

Tilslutning af Satellithøjttaler

Anschluss des Satelliten-Lautsprechers

Conexión del altavoz satélite

Raccordement des cubes

Collegamento dei diffusori a cubetto

Verbinding van de satelliet-luidsprekers

Anslutning av satellithögtalare

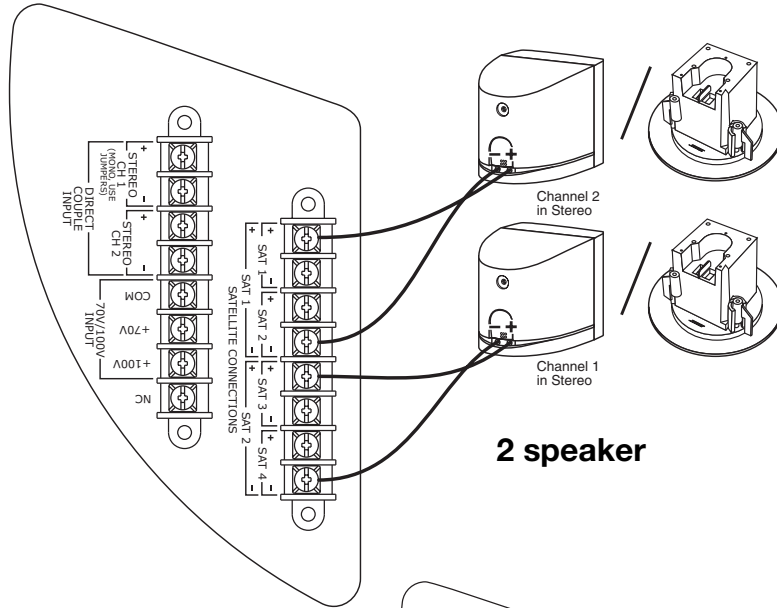

2 speaker

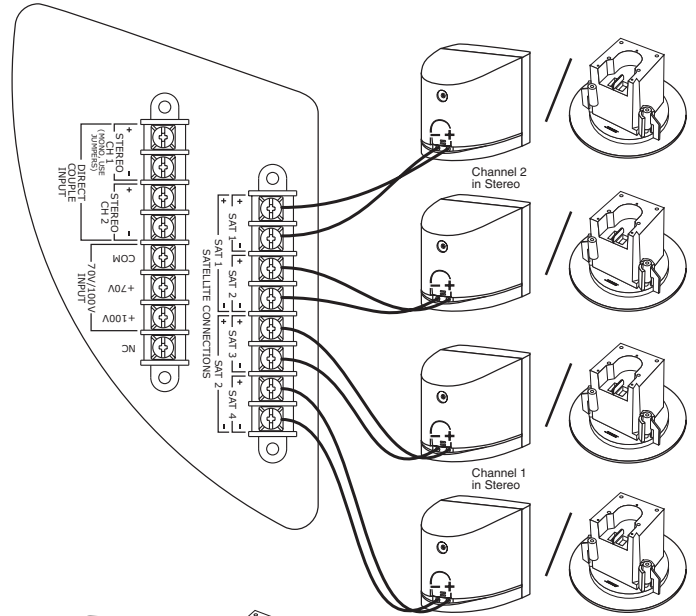

4 speaker

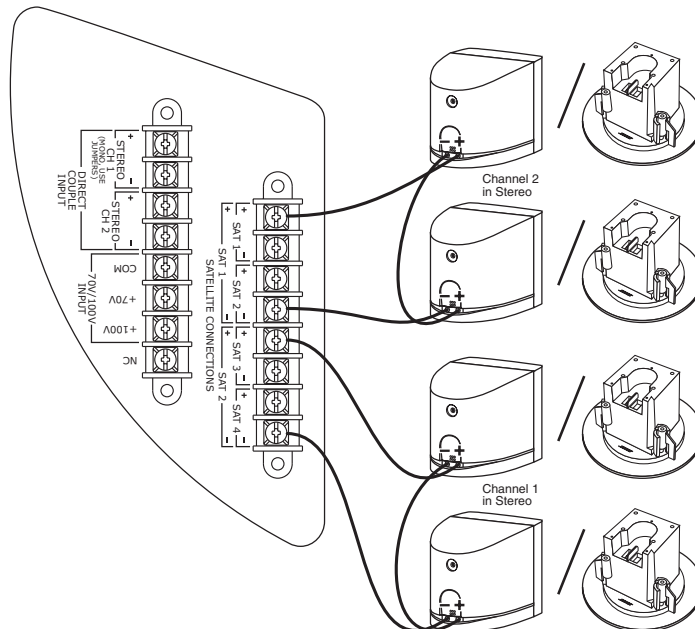

4 speaker in series

Using other compatible Bose® speakers

Anvendelse af andre kompatible Bose højttalere

Verwendung von anderen kompatiblen Lautsprechern von Bose

Uso de otros altavoces compatibles con Bose

Utilisation d'autres enceintes Bose compatibles

Impiego di altri diffusori compatibili della Bose

Gebruik van andere compatibele luidsprekers van Bose

Användning av andra Bose-kompatibla högtalare

- You can use the FreeSpace® 3 System Series II Acoustimass® module with other Bose® speakers, such as the FreeSpace Model 16, Model 32, Model 32SE, Panaray® 302™, or FreeSpace 6 speakers. Just be sure to connect both the speakers and the module directly to the amplifier, using separate channels or connect speakers that do not need equalization in parallel with the Acoustimass module on the same channel.

Caution: Do not connect any speakers, other than FreeSpace 3 satellite speakers, directly to the module.

- FreeSpace 3, serie II Acoustimass modulet kan anvendes med andre Bose højttalere, såsom FreeSpace Model 816, Model 32, Model 32SE, Panaray 302 eller FreeSpace 6 højttalere. Sørg blot for at tilslutte både højttalerne og modulet direkte til forstærkeren via separate udgange eller tilslutte højttalere, som ikke behøver equalizer i parallel med Acoustimass-modulet på den samme kanal.

Advarsel: Der må ikke sluttes andre højttalere end FreeSpace 3 satellithøjttalere direkte til modulet.

- Das FreeSpace 3 Series II Acoustimass Modul kann mit anderen Bose Lautsprechern eingesetzt werden, wie zum Beispiel dem FreeSpace Modell 16, Modell 32, Modell 32SE, Panaray 302 oder dem FreeSpace 6 Lautsprecher. Stellen Sie jedoch sicher, dass sowohl die Lautsprecher als auch das Modul direkt an den Verstärker angeschlossen und separate Kanäle benutzt werden, oder schließen Sie Lautsprecher, bei denen keine Entzerrung erforderlich ist, parallel zum Acoustimass Modul an denselben Kanal an.

Vorsicht: Schließen Sie nur FreeSpace 3 Satelliten-Lautsprecher direkt an das Modul an.

- Puede utilizar el módulo Acoustimass FreeSpace 3 Serie II con otros altavoces Bose, como los altavoces FreeSpace Modelo 16, Modelo 32, Modelo 32SE, Panaray 302 o FreeSpace 6. Asegúrese de conectar ambos altavoces y el módulo directamente al amplificador, utilizando canales separados, o, si son altavoces que no necesitan ecualizador en paralelo, conéctelos al módulo Acoustimass en el mismo canal.

Precaución: No conecte directamente al módulo ningún altavoz que no sea altavoz satélite FreeSpace 3.

- Il est possible de raccorder d'autres enceintes Bose sur le module Acoustimass, FreeSpace 3 série II, notamment les FreeSpace Model 16, Model 32, Model 32SE, Panaray 302 ou FreeSpace 6. S'assurer uniquement de raccorder directement les enceintes et le module sur des canaux séparés de l'amplificateur ou connecter les enceintes qui ne nécessitent pas d'égalisation en parallèle avec le module Acoustimass sur le même canal.

Attention : ne jamais connecter d'enceintes, autres que les cubes FreeSpace 3, directement sur le module.

- Il modulo Acoustimass FreeSpace 3 Serie II può essere usato con altri diffusori Bose come FreeSpace Modello 16, Modello 32, Modello 32SE, Panaray 302 o FreeSpace 6, purché il collegamento all'amplificatore sia diretto e vengano utilizzati due canali separati: uno per il modulo ed uno per i diffusori. In alternativa, i diffusori che non richiedono equalizzazione possono essere collegati in parallelo con il modulo Acoustimass sullo stesso canale.

Attenzione: non collegare altri diffusori, eccetto i diffusori a cubetto FreeSpace 3, direttamente al modulo.

- U kunt de FreeSpace 3 Series II Acoustimass Module met andere luidsprekers van Bose gebruiken zoals FreeSpace Model 16, Model 32, Model 32SE, Panaray® 302™ of FreeSpace 6 luidsprekers. Zorg er wel voor dat u zowel de luidsprekers als de module rechtstreeks op de daarvoor geschikte versterker aansluit d.m.v. aparte ingangen of dat u luidsprekers die niet gelijkgesteld hoeven te worden parallel met de Acoustimass Module op dezelfde ingang aansluit.

Opgelet: Sluit andere luidsprekers, met uitzondering van de FreeSpace 3 satellietluidsprekers niet rechtstreeks op de module aan.

- Du kan använda FreeSpace 3 Series II Acoustimass-modulen med andra Bose-högtalare, t ex FreeSpace Model 16, Model 32, Model 32SE, Panaray 302 eller FreeSpace 6. Se till att du ansluter både högtalarna och modulen direkt till förstärkaren på separata kanaler, eller ansluter högtalare som inte behöver utjämning parallellt med Acoustimass-modulen på samma kanal.

Varning: Anslut aldrig några högtalare förutom FreeSpace 3-satellithögtalarna direkt till modulen.

Mounting the module

Montering til modulet

Aufbau des Moduls

Montaje del módulo

Fixation du module

Installazione

Monteren van de module

Montering för modulen

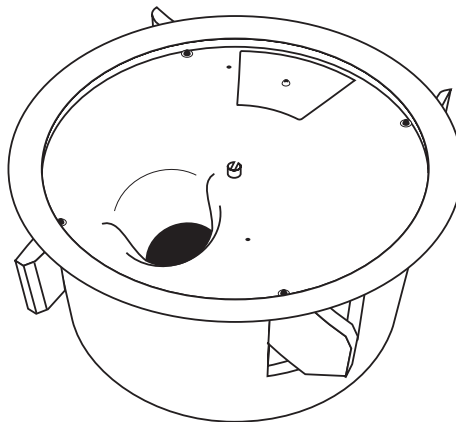

- Choose a mounting position, method, and hardware consistent with local building codes and regulations.
- Vælg monteringssted, -metode og tilbehør, der er i overensstemmelse med lokale byggevedtægter.
- Wählen Sie hierzu mit den örtlich gültigen Vorschriften übereinstimmende Befestigungspositionen, -methoden und materialien.
- Elija una posición y un método de montaje, y accesorios de acuerdo a los códigos y las regulaciones para edificios de su localidad.
- Choisir une position, une méthode et des accessoires de montage conformes aux règles et normes en vigueur pour ce type d'installation dans un bâtiment.
- Scegliere la posizione, il metodo e la ferramenta di montaggio in conformità alle normative edilizie e sugli impianti elettrici vigenti.
- Kies een montagepositie, -methode en schroeven e.d. die overeenkomen met plaatselijke bouwverordeningen en regulaties.
- Välj en monteringsposition, metod och hårdvara som uppfyller lokal byggkod och bestämmelser.

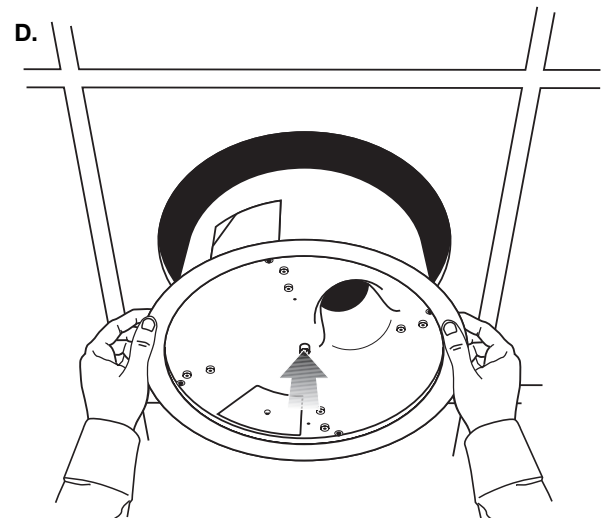
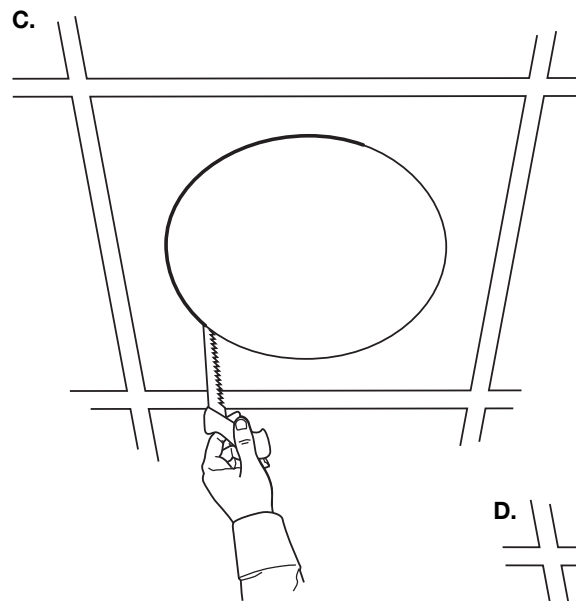
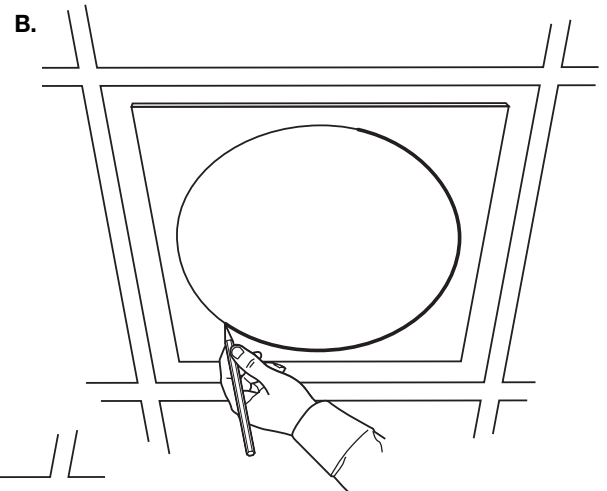
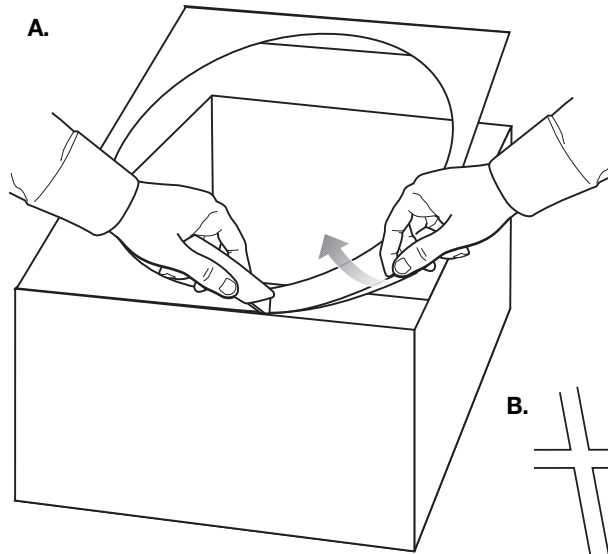

D.

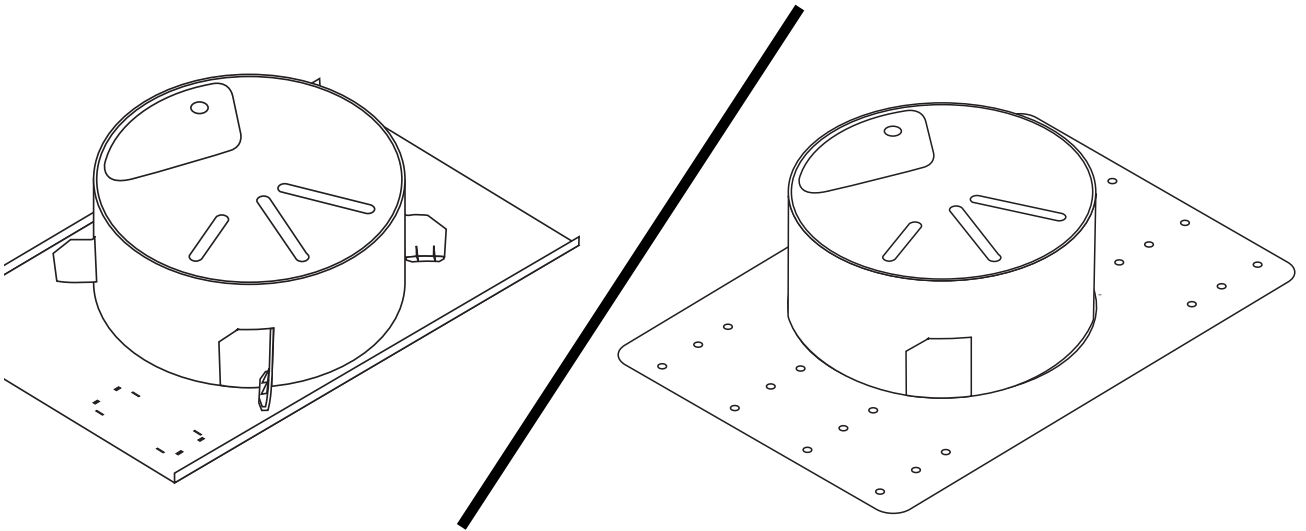

E.

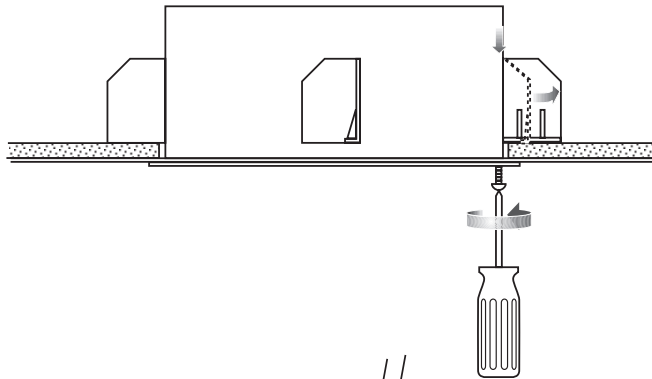

F.

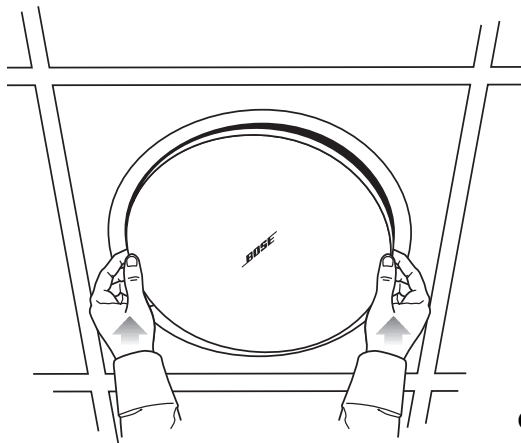

G.

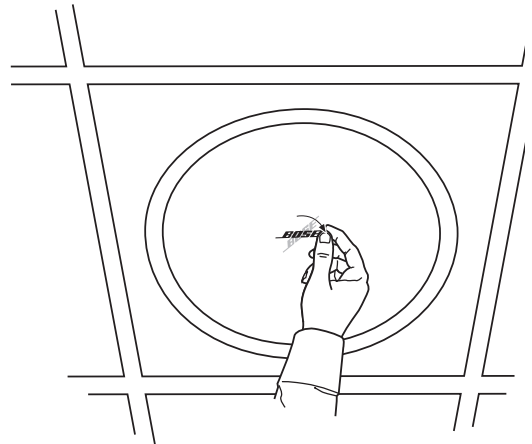

Mounting and wiring satellite speakers

Montering og lednings-fremføring til satellithøjtalere

Aufbau und Verdrahtung von Satelliten-Lautsprechern

Montaje y cableado de altavoces satélite

Fixation et câblage des cubes

Installazione e collegamento dei diffusori a cubetto

Monteren en bedraden van de satelliet-luidsprekers

Montering och kabeldragning för satellit-högtalare

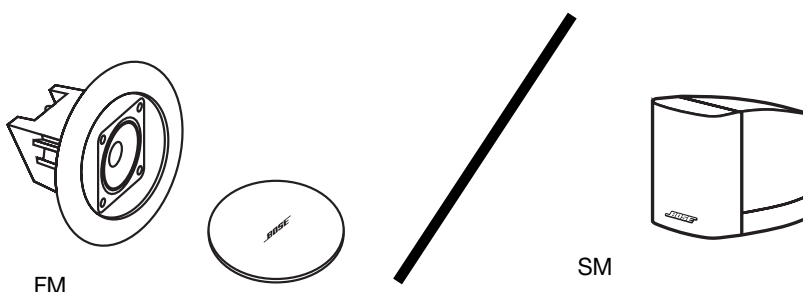

- Choose a position and mounting method consistent with local building codes and regulations.
- Vælg monteringssted, -metode der er i overensstemmelse med lokale byggevedtægter.
- Wählen Sie hierzu eine mit den örtlich gültigen Vorschriften übereinstimmende Befestigungsposition und -methode.
- Elija una posición y un método de montaje de acuerdo a los códigos y las regulaciones para edificios de su localidad.
- Choisir une position et une méthode de montage conformes aux règles et normes en vigueur pour ce type d'installation dans un bâtiment.
- Scegliere la posizione e il metodo di montaggio in conformità alle normative edilizie e sugli impianti elettrici vigenti.
- Kies een positie en montagemethode die overeenkomt met plaatselijke bouwverordeningen en regulaties.
- Välj en plats och en monteringsmetod som uppfyller byggkod och bestämmelser.

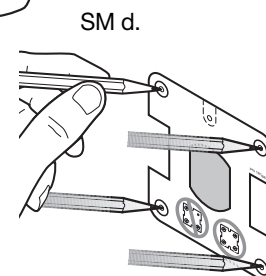
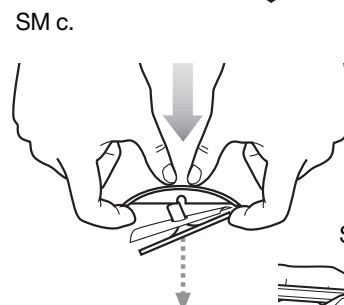
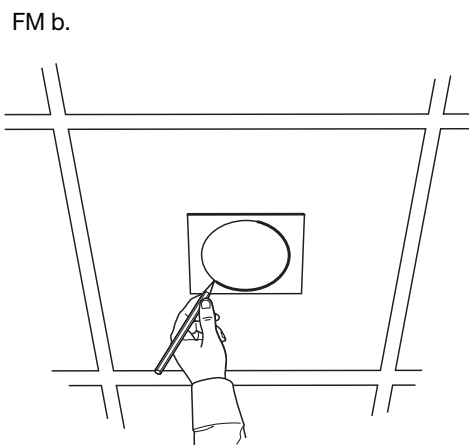
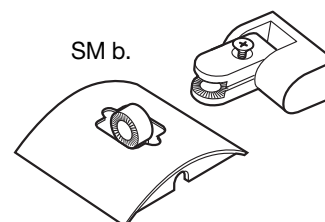
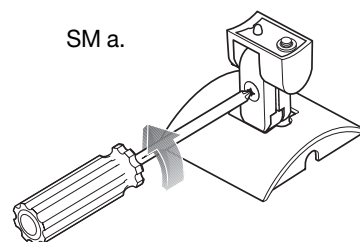
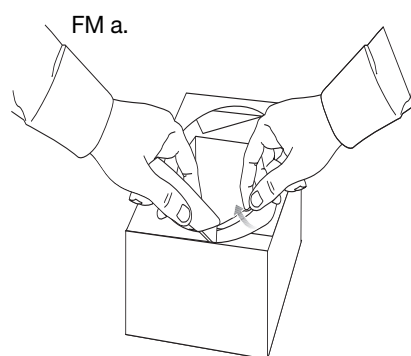

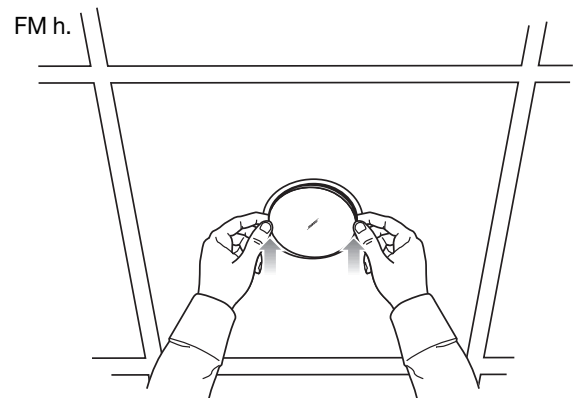
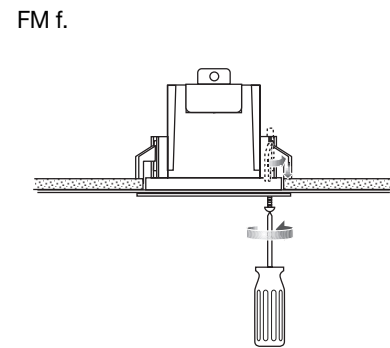
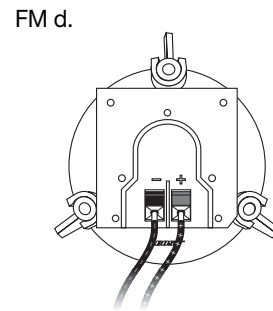
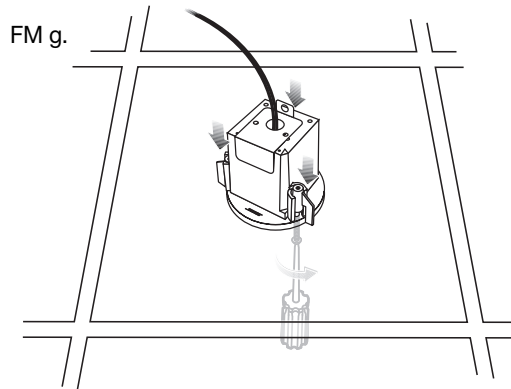
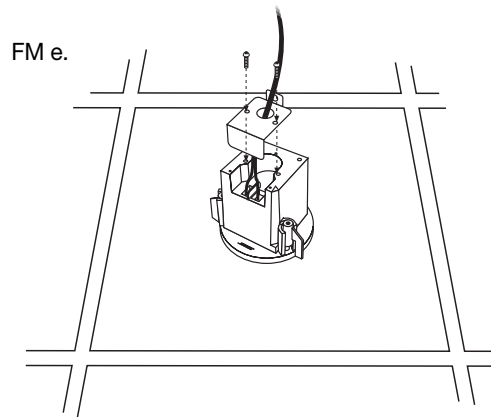
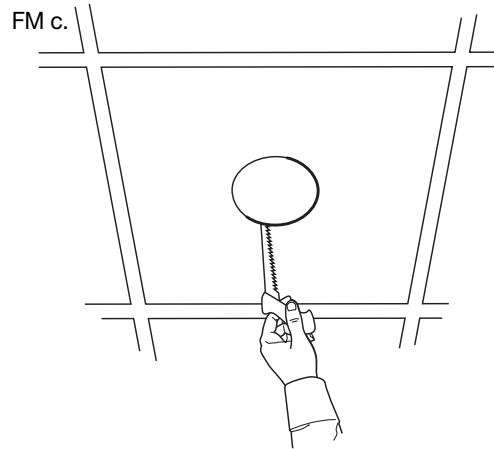

- Use four screws per bracket.
- Brug fire skruer per beslag.
- Benutzen Sie vier Schrauben pro Halter.
- Utilice cuatro tornillos por abrazadera.
- Chaque support doit être fixé par 4 vis.
- Usare quattro viti per ogni staffa.
- Gebruik vier schroeven per beugel.
- Använd fyra skruvar per konsol.

SM e.

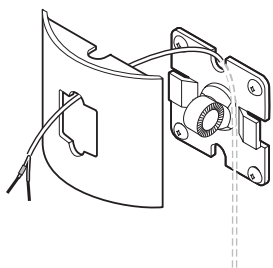

SM f.

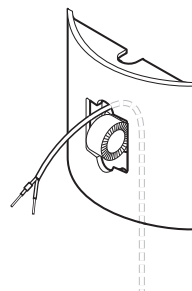

SM g.

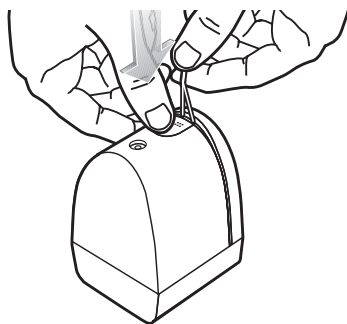

SM h.

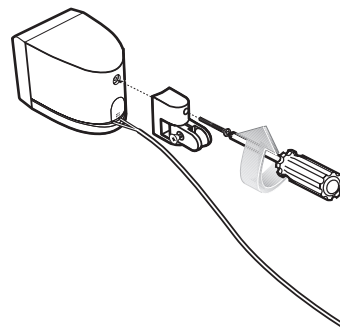

SM i.

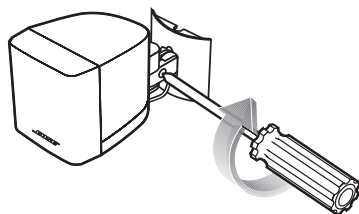

SM j.

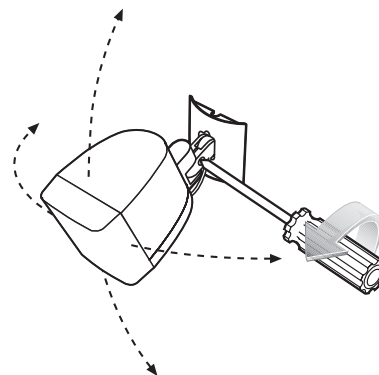

SM k.

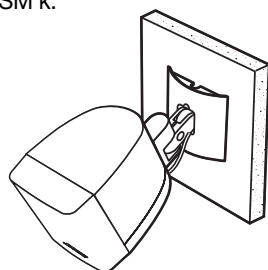



BOSE[®]
Better sound through research[®]

©2002 Bose Corporation, The Mountain
Framingham, MA 01701-9168 USA
263579 AM Rev.01 JN30604