

TABLE A

RoHS Compliant

SPECIFICATIONS:

- 1.RATING:100V AC 1A MAX
- 2.INSULATION RESISTANCE: 50M OHM MIN AT 500V DC.
3. DIELECTRIC STRENGTH: 500V AC / 1 MINUTE.
- 4.INSERTION FORCE: 4.5KG MAX.
- 5.WITHDRAWAL FORCE: 0.9KG ~ 3KG.

MATERIAL:
 A.COVER: EVA+PE-LL
 B.SHELL: ABS(PA-757)
 C.METAL SHIELD:
 BRASS NICKEL PLATED
 D.HOUSING: PA6
 E.CONTACT:
 BRASS SILVER PLATED

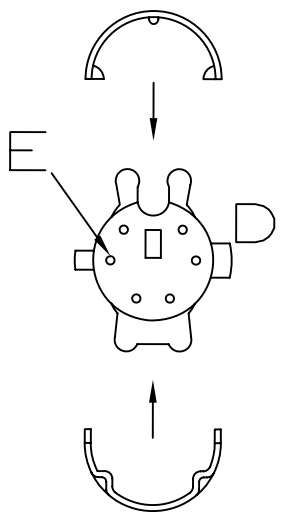

	7.0φ BACK SHELL
	6.0φ BACK SHELL
	5.0φ BACK SHELL (STANDARD)
	COVER DIM.

TABLE A

笙龍實業有限公司 SONION INDUSTRIAL CO., LTD.	
TOLERANCES .x ± 0.2 .xxx ± .xx ± 0.1 ANGLES	PART NUMBER 62000SER
DRAFT W.RAY050410'	DESCRIPTION Mini Din plug Ass'y Type
CHECK JANNE HUNG	REV. 050410'
APPROVAL DANNY HSU	SHEET 1/1

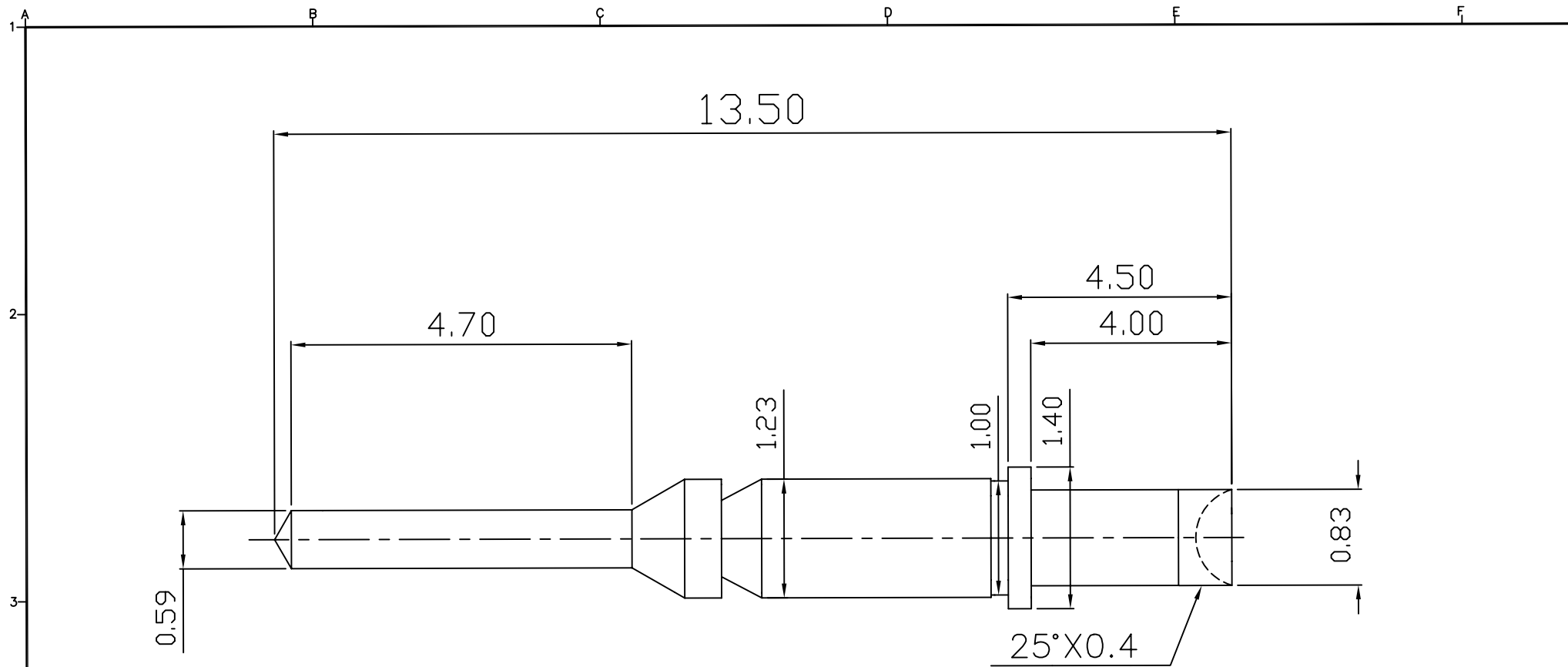

1. 材質/MATERIAL:
 - 1-1. 針/PIN: 黃銅 /BRASS
2. 電鍍/PLATING:
 - 2-1. 針/PIN: 銀 1-3u” /SILVER 1-3u”

繪圖 DRAW. BY	SHERRY	日期 DATE	29/10/01	單位 UNIT	MM	一般公差 TOLERANCE		筓龍實業有限公司 SONION INDUSTRIAL CO., LTD.	品名 ITEM	62000 SERIES PIN(銀)		SHEET 1
審核 APPVL. BY		版本 VERSION	第一版	比例 SCALE	5:1	.x ±0.1 .xx ±0.05			料號 PART NO.	62000 PIN	圖號 DWG NO.	011024A2

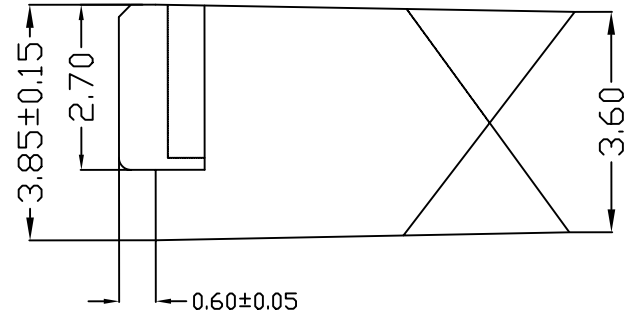
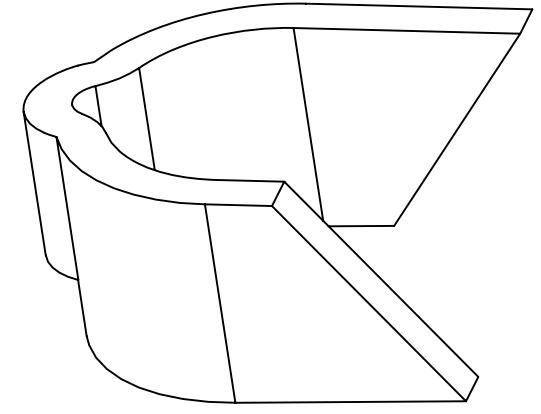
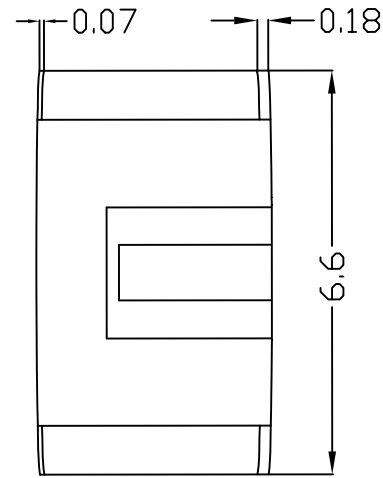
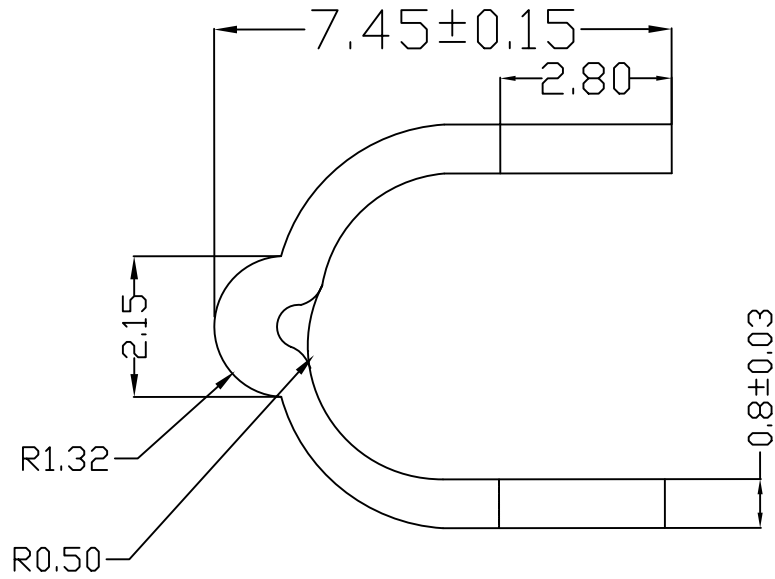

NOTES

1. MATERIAL: Fe 0.8t

NICKEL PLATED

 笙龍實業有限公司 SONION INDUSTRIAL CO., LTD.	
TOLERANCES $.x \pm 0.15$ $.xxx \pm$ / $.xx \pm 0.1$ ANGLES /	PART NUMBER SR
DRAFT W.RAY013105'	DESCRIPTION SR FOR MINI DIN SERIES
CHECK JANNE HUNG	REV. A
APPROVAL DANNY HSU	SHEET 1/1