



evolution wireless G4

SKP 100 G4 | Plug-on Transmitter



Powerful plug-on transmitter that turns every wired dynamic microphone into a wireless transmitter for evolution wireless G4 100P Series systems. For documentary, Mobile Journalism and audio for video applications.

FEATURES

- Powerful camera receiver, easily mounted on any kind of camera
- Excellent sound and construction quality
- Easy to use and fast setup time
- Powerful and reliable wireless transmission
- Range: up to 100 meters / 330 feet
- Up to 8 hours of operation time

DELIVERY INCLUDES

- SKP 100 G4 plug-on transmitter
- 2 AA batteries
- quick guide
- safety guide
- manufacturer declaration sheet

ACCESSORIES

BA 2015 rechargeable battery Art. no. 009950

PRODUCT VARIANTS

Made in Germany

SKP 100 G4-A1	470 - 516 MHz	Art. no. 507652
SKP 100 G4-A	516 - 558 MHz	Art. no. 507653
SKP 100 G4-GB	606 - 648 MHz	Art. no. 507654
SKP 100 G4-G	566 - 608 MHz	Art. no. 507655
SKP 100 G4-B	626 - 668 MHz	Art. no. 507656
SKP 100 G4-C	734 - 776 MHz	Art. no. 507657
SKP 100 G4-E	823 - 865 MHz	Art. no. 507658
SKP 100 G4-K+	925 - 937.5 MHz	Art. no. 507659

Assembled in USA

SKP 100 G4-A1	470 - 516 MHz	Art. no. 507993
SKP 100 G4-A	516 - 558 MHz	Art. no. 507994
SKP 100 G4-AS	520 - 558 MHz	Art. no. 507995
SKP 100 G4-G	566 - 608 MHz	Art. no. 507996
SKP 100 G4-B	626 - 668 MHz	Art. no. 507997
SKP 100 G4-C	734 - 776 MHz	Art. no. 507998
SKP 100 G4-D	780 - 822 MHz	Art. no. 507999
SKP 100 G4-JB	806 - 810 MHz	Art. no. 508000



evolution wireless G4

SKP 100 G4 | Plug-on Transmitter

SPECIFICATIONS

RF characteristics	
Modulation	Wideband FM
Frequency ranges	A1: 470 - 516 MHz A: 516 - 558 MHz AS: 520 - 558 MHz G: 566 - 608 MHz GB: 606 - 648 MHz B: 626 - 668 MHz C: 734 - 776 MHz D: 780 - 822 MHz E: 823 - 865 MHz JB: 806 - 810 MHz K+: 925 - 937.5 MHz
Transmission frequencies	Max. 1680 frequencies, adjustable in 25 kHz steps 20 frequency banks, each with up to 12 factory-preset channels, no intermodulation 1 frequency bank with up to 12 programmable channels
Switching bandwidth	up to 42 MHz
Nominal/peak deviation	± 24 kHz / ± 48 kHz
Frequency stability	$\leq \pm 15$ ppm
RF output power at 50 Ω	Max. 30 mW
Pilot tone squelch	Can be switched off

AF characteristics	
Compander system	Sennheiser HDX
AF frequency response	80 – 18,000 Hz
Signal-to-noise ratio (1 mV, peak deviation)	≥ 110 dBA
Total harmonic distortion (THD)	≤ 0.9 %
Max. input voltage	3.3 V _{eff}
Input impedance	68 k Ω , unbalanced
Input capacitance	Switchable
Setting range for input sensitivity	48 dB, adjustable in 6 dB steps

Overall device	
Temperature range	-10 °C to +55 °C
Power supply	2 AA batteries, 1.5 V or BA 2015 accupack
Nominal voltage	3 V battery / 2.4 V rechargeable battery
Current consumption	at nominal voltage: typ. 180 mA with transmitter switched off: ≤ 25 μ A
Operating time	Typically 8 h
Dimensions	Approx. 105 x 43 x 43 mm
Weight (incl. batteries)	approx. 195 g



evolution wireless G4

SKP 100 G4 | Plug-on Transmitter

DIMENSIONS

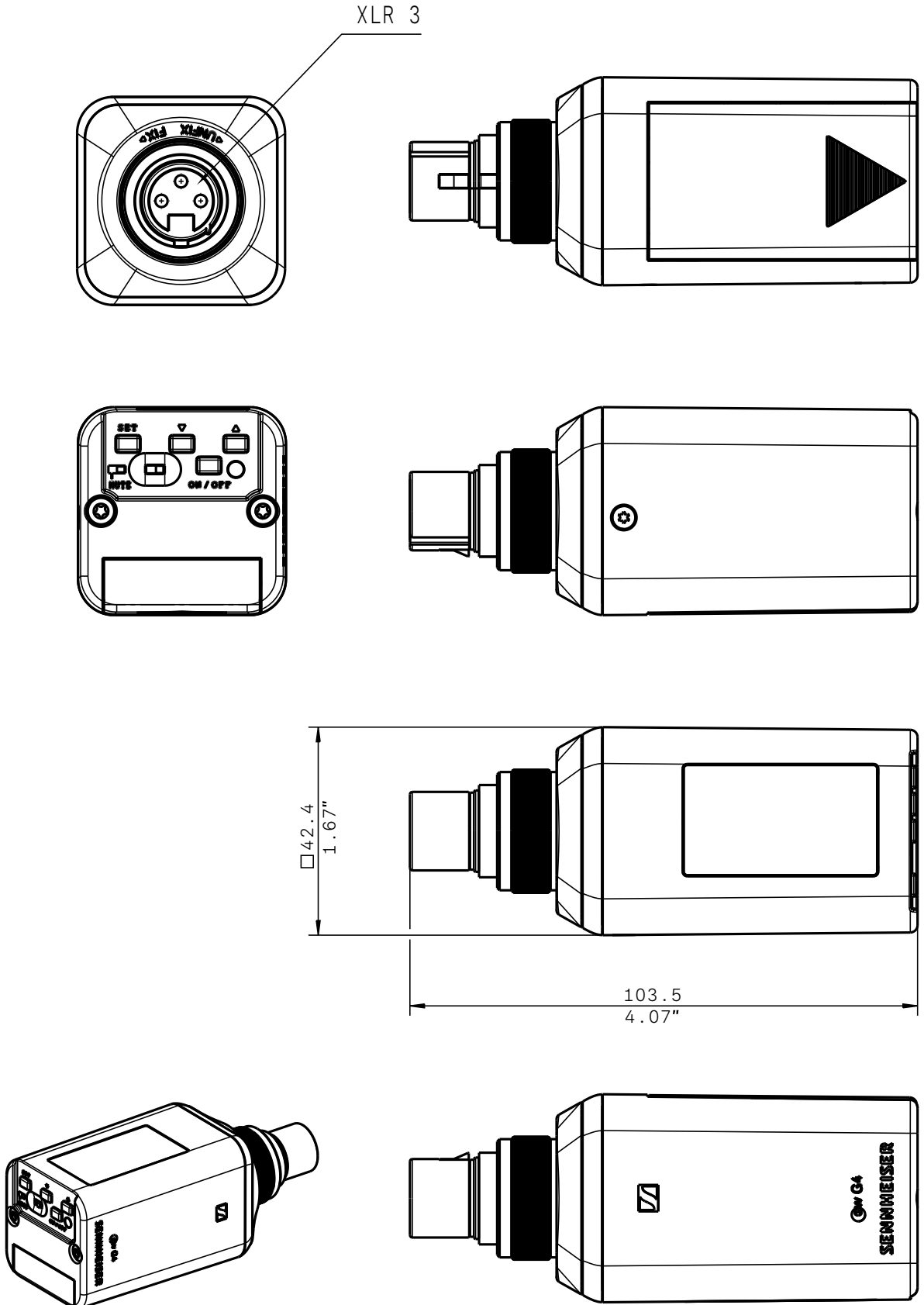



evolution wireless G4

SKP 100 G4 | Plug-on Transmitter

ARCHITECT'S SPECIFICATION

The plug-on transmitter shall be for use to turn XLR-equipped microphones into wireless ones as part of a wireless RF transmission system.

The transmitter shall operate within eleven UHF frequency ranges, with a switching bandwidth of up to 42 MHz: 470 – 516 MHz, 516 – 558 MHz, 520 – 558 MHz, 566 – 608 MHz, 606 – 648 MHz, 626 – 668 MHz, 734 – 776 MHz, 780 – 822 MHz, 823 – 865 MHz, 806 – 810 MHz, 925 – 937.5 MHz; receiving frequencies shall be 1,680 per range and shall be tunable in 25 kHz steps. The transmitter shall feature 20 fixed frequency banks with up to 12 compatible frequency presets and 1 user bank with up to 12 user programmable frequencies.

The transmitter shall be menu-driven with a backlit LC display showing the current frequency, frequency bank and channel number, metering of AF level, lock status, pilot tone evaluation, muting function, and battery status. An auto-lock feature shall be provided to prevent settings from being accidentally altered. Some transmitter parameters such as receiving frequency, transmitter name and pilot tone setting shall be synchronizable with the associated transmitter via an integrated infrared interface.

The transmitter shall be equipped with a mute switch, which shall be switchable between “AF on/off”, “RF on/off” and “Disabled” via the user interface. The transmitter shall feature an Audio-XLR-3F connector.

Nominal/peak deviation shall be ± 24 kHz/ ± 48 kHz. Frequency stability shall be $\leq \pm 15$ ppm. RF output power at 50 Ω shall be max. 30 mW.

The transmitter shall incorporate the Sennheiser HDX compander system and a defeatable pilot tone squelch. Audio frequency response shall range from 80 – 18,000 Hz. Signal-to-noise ratio at 1 mV and peak deviation shall be ≥ 110 dBA. Total harmonic distortion (THD) shall be ≤ 0.9 %. The Transmitters max. input voltage shall be 3.3 Veff; the unbalanced input impedance shall be 68 k Ω ; the input capacitance shall be switchable. The input sensitivity shall be adjustable within a 48 dB range in steps of 6 dB.

Power shall be supplied to the transmitter by two 1.5V AA size batteries or by one Sennheiser BA 2015 rechargeable accupack. Nominal voltage shall be 2.4 V, current consumption shall be typical 180 mA at nominal voltage; ≤ 25 μ A when transmitter is switched off. Operating time shall be typical 8 hours. The transmitter shall have a rugged metal housing; dimensions shall be approximately 105 x 43 x 43 mm (4.13" x 1.69" x 1.69"). Weight including the batteries shall be approximately 195 grams (0.43 lbs). Operating temperature shall range from -10 °C to $+55$ °C ($+14$ °F to $+131$ °F).

The transmitter shall be the Sennheiser SKP 100 G4.