

AT-100a Wideband Circularly Polarized Antenna

Introduction

Patented in Multiple Countries. Distinctive Appearance

Providing an optimized solution for both transmitting and receiving RF signals throughout the UHF bandwidth, the AT-100a has a distinctive appearance and is patented in multiple countries.

Main Features

The front area is the main focus of antenna direction for either vertical or horizontal polarization. The AT-100a circularly polarized antenna can effectively reduce the polarization loss of the antenna to improve signal strength. It is the optimum solution for the 470 – 1,000 MHz bandwidth with 6 – 8 dBi antenna gain and is certified to meet the latest CE/FCC new telecom regulations.

Results

The AT-100a is an ideal antenna system for utmost signal stability. Antenna features affect transmission range, stability and anti-interference performance. Therefore, the antenna is a vital component in any system installation, especially in complicated and demanding RF environments for wireless microphones and wireless monitoring systems. It greatly improves signal stability and reduces interference and signal drop-outs caused by polarization problems.

Built-in Connectors

The AT-100a has two built-in signal connectors: "TX/RX" connector can be connected to a transmitter or receiver, however, connection to a short coaxial cable is recommended when connected to a receiver. "RX" connector (cannot be connected to a transmitter) has a built-in 0 – 12 ± 1 dB gain adjustable booster and thus provides extended reception range and compensates the signal loss of coaxial cable to improve reception range and signal quality. The power of gain controllable booster can be provided by a MIPRO AD-708 antenna divider or any MIPRO ACT Series receivers which provides bias by adding an adjustor on their antenna connectors.

Waterproof

Waterproof and weather resistant, the AT-100a is ideal for both outdoor and indoor applications.



Accessories

MS-30	Tripod Microphone Stand
MS-90	Wall Mount

Technical Specifications

Frequency Range	UHF 470 – 1,000 MHz
Antenna Gain	6 – 8 dBi
Polarization	Circular polarization
3-dB Beam Width	72°
Booster Gain	RX Connector: 0 – 12 ± 1 dB gain adjustable; TX/RX Connector: 0 dB
VSWR	< 2:1
Voltage Range of RX Connector	8 – 15 V DC
Power Consumption	RX Connector: 1.3 W / 8 V DC; TX Connector: 0 mW
Impedance	50 Ω
Connectors	TNC female × 2
Dimensions (W × H × D)	350 × 350 × 225 mm / 13.8 × 13.8 × 8.8 "
Weight	1.5 kg / 3.3 lbs

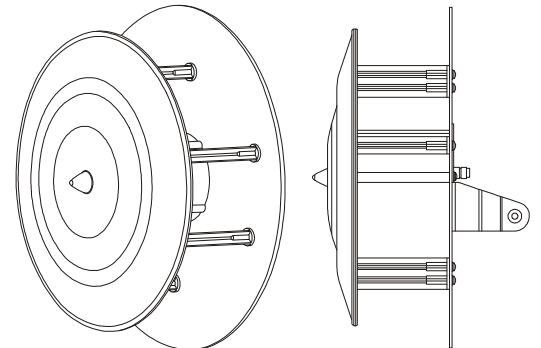

MIPRO Electronics Co., Ltd

Headquarters: 814 Pei-kang Road, Chiayi, 60096, Taiwan
Tel: +886.5.238.0809 | Fax: +886.5.238.0803
www.mipro.com.tw | mipro@mipro.com.tw