



Spectral CYC650

V2

ORDERCODE 43519



Highlite International B.V.
Vestastraat 2
6468 EX Kerkrade
The Netherlands
Phone: +31 45-5667700

SHOWELECTRONICS FOR PROFESSIONALS

Congratulations!

You have bought a great, innovative product from Showtec.

The Showtec Spectral CYC650 brings excitement to any venue. Whether you want simple plug-&-play action or a sophisticated DMX show, this product provides the effect you need.

You can rely on Showtec, for more excellent lighting products.

We design and manufacture professional light equipment for the entertainment industry.

New products are being launched regularly. We work hard to keep you, our customer, satisfied.

For more information: iwant@showtec.info

You can get some of the best quality, best priced products on the market from Showtec.

So next time, turn to Showtec for more great lighting equipment.

Always get the best -- with Showtec !

Thank you!



Showtec Spectral CYC650™ Product Guide

Warning2
Safety Instructions2
Operating Determinations.....4
Rigging4
Return Procedure5
Claims.....5

Description of the device6
DMX Channel Summary.....7
Overview8
Backside.....8

Installation8

Set Up and Operation.....8
Control Modes9
One Spectral (Static Colors)9
One Spectral (Built-in Programs)9
Multiple Spectrals (Master/Slave control)9
Multiple Spectrals (DMX Control)9
Fixture Linking10
Data Cabling10
Control Panel11
DMX Control Mode11
DMX Addressing11
Menu Overview12
Main Menu Options13
1. Creating a static color13
2. Activating an Auto Program.....14
3. DMX 512 Address14
4. Run Mode.....15
5. Personality15
6. Changing the Settings16
7. FACTORY DEFAULT SETTINGS.....16
8. Edit Custom.....17
9. Fans17
10. White Settings18
11. White Settings (RGB Recalibration).....18
12. Activate Password18
How to make your own Custom Program19

DMX MODES20
10-Channel (TOUR)20
24-Channel (PIXEL).....22
3-Channel (ARC1).....23
4-Channel (ARC1+D).....23
3-Channel (HSV)23

Beam Angles.....24

Connection Cables.....25

Maintenance25
Replacing a Fuse.....25

Troubleshooting26
No Light26
No Response to DMX.....26

Product Specification28

Warning

**FOR YOUR OWN SAFETY, PLEASE READ THIS USER MANUAL CAREFULLY
BEFORE YOUR INITIAL START-UP!**

Unpacking Instructions

Immediately upon receiving this product, carefully unpack the carton and check the contents to ensure that all parts are present, and have been received in good condition. Notify the dealer immediately and retain packing material for inspection if any parts appear damaged from shipping or the carton itself shows signs of mishandling. Save the carton and all packing materials. In the event that a fixture must be returned to the factory, it is important that the fixture be returned in the original factory box and packing.

Your shipment includes:

- Spectral CYC650
- 1X safety cable
- User manual



LED Expected Lifespan

LEDs gradually decline in brightness over time. HEAT is the dominant factor that leads to the acceleration of this decline. Packaged in clusters, LEDs exhibit higher operating temperatures than in ideal or singular optimum conditions. For this reason when all color LEDs are used at their fullest intensity, life of the LEDs is significantly reduced. It is estimated that a viable lifespan of 40,000 to 50,000 hours will be achieved under normal operational conditions. If improving on this lifespan expectancy is of a higher priority, place care in providing for lower operational temperatures. This may include climatic-environmental and the reduction of overall projection intensity.

Safety Instructions

Every person involved with the installation, operation and maintenance of this device has to:

- be qualified
- follow the instructions of this manual



**CAUTION! Be careful with your operations.
With a dangerous voltage you can suffer
a dangerous electric shock when touching the wires!**



Before your initial start-up, please make sure that there is no damage caused by transportation. Should there be any, consult your dealer and do not use the device.

To maintain perfect condition and to ensure a safe operation, it is absolutely necessary for the user to follow the safety instructions and warning notes written in this manual.

Please consider that damages caused by manual modifications to the device are not subject to warranty.

This device contains no user-serviceable parts. Refer servicing to qualified technicians only.

IMPORTANT:

The manufacturer will not accept liability for any resulting damages caused by the non-observance of this manual or any unauthorized modification to the device.

- Never let the power-cord come into contact with other cables! Handle the power-cord and all connections with the mains with particular caution!
- Never remove warning or informative labels from the unit.
- Never use anything to cover the ground contact.
- Never look directly into the light source.
- Never leave any cables lying around.
- Never use the device during thunderstorms, unplug the device immediately.
- Never leave various parts of the packaging (plastic bags, polystyrene foam, nails, etc.) within children's reach, as they are potential sources of danger.
- Do not insert objects into air vents.
- Do not open the device and do not modify the device.
- Do not connect this device to a dimmerpack.
- Do not shake the device. Avoid brute force when installing or operating the device.
- Do not switch the device on and off in short intervals, as this would reduce the system's life.
- Only use device indoor, avoid contact with water or other liquids.
- Only operate the device after having familiarized with its functions.
- Avoid flames and do not put close to flammable liquids or gases.
- Always allow free air space of at least 50 cm around the unit for ventilation.
- Always disconnect power from the mains, when device is not used or before cleaning! Only handle the power-cord by the plug. Never pull out the plug by tugging the power-cord.
- Make sure that the device is not exposed to extreme heat, moisture or dust.
- Make sure that the available voltage is not higher than stated on the rear panel.
- Make sure that the power-cord is never crimped or damaged. Check the device and the power-cord from time to time.
- Make sure that no side forces can impact on the truss system.
- The cable insert or the female part in the device must never be strained. There must always be sufficient cable to the device. Otherwise, the cable may be damaged which may lead to deadly electrical shocks.
- If the external cable is damaged, it has to be replaced by a qualified technician.
- If the lens is obviously damaged, it has to be replaced. So that its functions are not impaired, due to cracks or deep scratches.
- If device is dropped or struck, disconnect mains power supply immediately. Have a qualified engineer inspect for safety before operating.
- If the device has been exposed to drastic temperature fluctuation (e.g. after transportation), do not switch it on immediately. The arising condensation water might damage your device. Leave the device switched off until it has reached room temperature.
- If your Showtec device fails to work properly, discontinue use immediately. Pack the unit securely (preferably in the original packing material), and return it to your Showtec dealer for service.
- For adult use only. The device must be installed out of the reach of children. Never leave the unit running unattended.
- For replacement use fuses of same type and rating only.
- The user is responsible for correct positioning and operating of the Spectral CYC650. The manufacturer will not accept liability for damages caused by the misuse or incorrect installation of this device.
- This device falls under protection class I. Therefore it is essential to connect the yellow/green conductor to earth.
- Repairs, servicing and electric connection must be carried out by a qualified technician.
- WARRANTY: Till one year after date of purchase.



CAUTION ! EYEDAMAGES !
Avoid looking directly into the light source.
(meant especially for epileptics) !



Operating Determinations

- This device is not designed for permanent operation. Consistent operation breaks will ensure that the device will serve you for a long time without defects.
- The minimum distance between light-output and the illuminated surface must be more than 0.5 meter.
- The maximum ambient temperature $t_a = 45^\circ\text{C}$ must never be exceeded.
- The relative humidity must not exceed 50 % with an ambient temperature of 45°C .
- If this device is operated in any other way, than the one described in this manual, the product may suffer damages and the warranty becomes void.
- Any other operation may lead to dangers like short-circuit, burns, electric shock, crash etc.

You endanger your own safety and the safety of others!

Improper installation can cause serious damage to people and property !

Rigging

Please follow the European and national guidelines concerning rigging, trussing and all other safety issues.

Do not attempt the installation yourself !

Always let the installation be carried out by an authorized dealer !

Procedure:

- If the Spectral CYC650 is lowered from the ceiling or high joists, professional trussing systems have to be used.
- Use a clamp to mount the Spectral CYC650, with the mounting-bracket, to the trussing system.
- The Spectral CYC650 must never be fixed swinging freely in the room.
- The installation must always be secured with a safety attachment, e.g. an appropriate safety net or safety-cable.
- When rigging, derigging or servicing the Spectral CYC650, always make sure, that the area below the installation place is blocked and staying in the area is forbidden.



The Spectral CYC650 can be mounted in a hanging position (Fig. Above) or Upright (Fig. Below), using the support brackets. Mounting the Spectral CYC650 with a clamp or any other mounting bracket is recommended, depending on the requirements of your application.



The Spectral CYC650 can be placed on a flat stage floor or mounted to any kind of truss by a clamp.

Improper installation can cause serious damage to people and property !

Connection with the mains

Connect the device to the mains with the power-plug.

Always pay attention, that the right color cable is connected to the right place.

International	EU Cable	UK Cable	US Cable	Pin
L	BROWN	RED	YELLOW/COPPER	FASE
N	BLUE	BLACK	SILVER	NUL
	YELLOW/GREEN	GREEN	GREEN	EARTH

Make sure that the device is always connected properly to the earth!



Return Procedure

Returned merchandise must be sent prepaid and in the original packing, call tags will not be issued. Package must be clearly labeled with a Return Authorization Number (RMA number). Products returned without an RMA number will be refused. Highlite will not accept the returned goods or any responsibility. Call Highlite 0031-455667723 or mail aftersales@highlite.nl and request an RMA prior to shipping the fixture. Be prepared to provide the model number, serial number and a brief description of the cause for the return. Be sure to properly pack fixture, any shipping damage resulting from inadequate packaging is the customer's responsibility. Highlite reserves the right to use its own discretion to repair or replace product(s). As a suggestion, proper UPS packing or double-boxing is always a safe method to use.

Note: If you are given an RMA number, please include the following information on a piece of paper inside the box:

- 1) Your name
- 2) Your address
- 3) Your phone number
- 4) A brief description of the symptoms

Claims

The client has the obligation to check the delivered goods immediately upon delivery for any shortcomings and/or visible defects, or perform this check after our announcement that the goods are at their disposal. Damage incurred in shipping is the responsibility of the shipper; therefore the damage must be reported to the carrier upon receipt of merchandise.

It is the customer's responsibility to notify and submit claims with the shipper in the event that a fixture is damaged due to shipping. Transportation damage has to be reported to us within one day after receipt of the delivery.

Any return shipment has to be made post-paid at all times. Return shipments must be accompanied with a letter defining the reason for return shipment. Non-prepaid return shipments will be refused, unless otherwise agreed in writing.

Complaints against us must be made known in writing or by fax within 10 working days after receipt of the invoice. After this period complaints will not be handled anymore.

Complaints will only then be considered if the client has so far complied with all parts of the agreement, regardless of the agreement of which the obligation is resulting.

Description of the device

Features

The Spectral CYC650 indoor/outdoor colour wash is a LED Bar from Showtec

- Combining the elements of smooth 3-in-1 LED color mixing with pixel animation effects.
- Ideal tool for entertainment applications of any size
- Suitable for use on floor to light up walls or decorations.
- Spectral CYC650 able to be slotted end-to-end or side-by-side creating an even more versatility in set design.
- Dim4 technology on board, which simulates the dimming curve of a halogen lamp and makes programming of flowing chases very easy.
- LED Quantity: 8x 3-in-1 LED
- 3-pin DMX In and 3-pin DMX Out (XLR 3 Pin)
- Neutrik Powercon Input and Output
- Multivoltage (100-240V)
- High light-output
- Drive current: 350mA
- Peak Power 154 Watt; Continuous Power 82 Watt
- On-board: Display for Auto and Custom control
- Control protocol: DMX 512
- Control personality: TOUR, PIXEL, ARC1, ARC1+D, HSV
- Dimmer: 0-100%
- Strobe: 0-20Hz
- Cooling: Forced Cooling (Fan)
- Overheat Protection
- 3, 3, 4, 10 or 24-channel LED wash light
- 4 different DMX Operating modes
- Colour temperature presets (3,200 K ~ 10,000 K)
- Built-in automated programs via DMX
- Recall custom programs via DMX
- LED display with lock-out feature
- Beam angle: 16°
- Fan Speed Control
- Max. Distance: 20m
- Output: Lumen: 640+
Lux @ 2m: 1500+
- Max. Distance: 20m
- Double-bracket doubles as floor stand
- Accessories: Included: Manual, safety cable, bracket
- Housing: Black Extruded aluminium
- Dimensions: 562 x 88 x 230 mm (LxWxH)
- Weight: 3,54 kg

NOTE: Knowledge of DMX is required to fully utilize this unit.

TOUR:	10 channels
PIXEL:	24 channels
ARC1:	3 channels
ARC1+D:	4 channels
HSV:	3 channels

DMX Channel Summary

TOUR	Channel	Description
	1	Master Dimmer
	2	Red
	3	Green
	4	Blue
	5	Color Macro
	6	Strobe
	7	Auto & Custom Programs
	8	Auto Speed Adjustment
	9	Dimmer Speed
	10	Block Sections

PIXEL	Channel	Description
	1	Pixel 1 Red
	2	Pixel 1 Green
	3	Pixel 1 Blue
	4	Pixel 2 Red
	5	Pixel 2 Green
	6	Pixel 2 Blue
	7	Pixel 3 Red
	8	Pixel 3 Green
	9	Pixel 3 Blue
	10	Pixel 4 Red
	11	Pixel 4 Green
	12	Pixel 4 Blue
	13	Pixel 5 Red
	14	Pixel 5 Green
	15	Pixel 5 Blue
	16	Pixel 6 Red
	17	Pixel 6 Green
	18	Pixel 6 Blue
	19	Pixel 7 Red
	20	Pixel 7 Green
	21	Pixel 7 Blue
	22	Pixel 8 Red
	23	Pixel 8 Green
	24	Pixel 8 Blue

ARC1	Channel	Description
	1	Red
	2	Green
	3	Blue

ARC1+D	Channel	Description
	1	Master Dimmer
	2	Red
	3	Green
	4	Blue

HSV	Channel	Description
	1	Hue
	2	Saturation
	3	Value

Overview



Fig. 1

- 1) Fixation Screw for variable Truss mounting
- 2) 8x 3-in-1 RGB LEDs
- 3) Mountingbracket for Truss mounting

Backside



Fig. 2

- 4) Earth
- 5) Fuse 0,5A / 250V
- 6) Power IN
- 7) Power OUT
- 8) DMX signal connector (IN) 3-pin
- 9) DMX signal connector (OUT) 3-pin
- 10) Safety eye
- 11) Fan
- 12) LCD Display

Installation

Remove all packing materials from the Spectral CYC650. Check that all foam and plastic padding is removed. Connect all cables.

Do not supply power before the whole system is set up and connected properly.
Always disconnect from electric mains power supply before cleaning or servicing.
Damages caused by non-observance are not subject to warranty.

Set Up and Operation

Before plugging the unit in, always make sure that the power supply matches the product specification voltage. Do not attempt to operate a 120V specification product on 230V power, or vice versa.

Control Modes

FUNCTIONS:

There are 4 modes:

- Static Colors
- Built-in programs Auto run
- Master/Slave
- DMX512 (3, 3, 4, 10 or 24 Channels)

One Spectral (Static Colors)

- 1) Fasten the effect light onto firm trussing. Leave at least 0,5 meter on all sides for air circulation.
- 2) When the Spectral is not connected by a DMX-cable, it functions as a stand-alone device. Please see page 13 for more information about the static colors.

One Spectral (Built-in Programs)

1. Fasten the effect light onto firm trussing. Leave at least 0,5 meter on all sides for air circulation.
2. When the Spectral is not connected by a DMX-cable, it functions as a stand-alone device. Please see page 14 for more information about the built-in programs.

Multiple Spectrals (Master/Slave control)

1. Fasten the effect light onto firm trussing. Leave at least 0,5 meter on all sides for air circulation.
2. Use a 3-p XLR cable to connect the Spectral.

The pins:



1. Earth
2. Signal -
3. Signal +

3. Link the units as shown in (Fig. 3), Connect a DMX signal cable from the first unit's DMX "out" socket to the second unit's "in" socket. Repeat this process to link the second, third, and fourth units. You can use the same functions on the master device as described on page 13+14 (Static Colors or Built-in Programs). This means on the master device you can set your desired operation Mode and all slave devices will react the same as the master device.

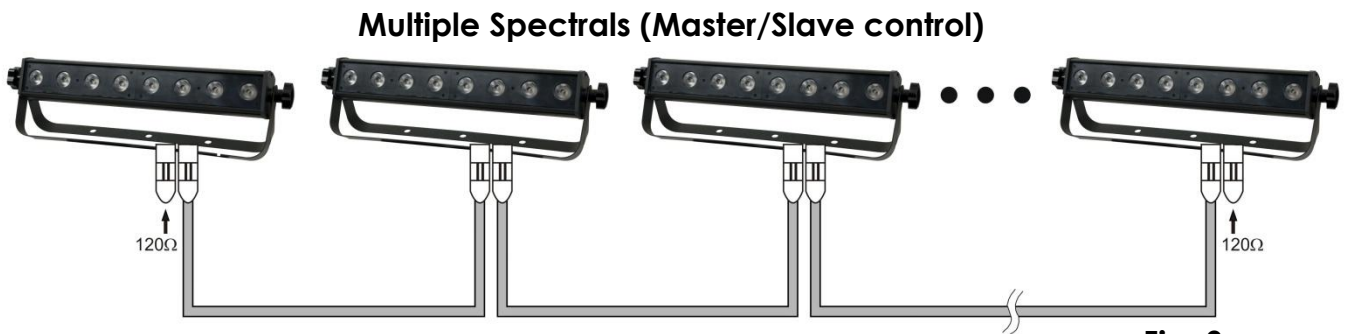

Fig. 3

Multiple Spectrals (DMX Control)

1. Plug the end of the electric mains power cord into a proper electric power supply socket.
2. Use a 3-p XLR cable to connect the Spectrals.
3. Link the units as shown in (figure 4), Connect a DMX signal cable from the first unit's DMX "out" socket to the second unit's "in" socket. Repeat this process to link the second, third, and fourth units.
4. Supply electric power: Plug the end of the mains power cord into proper electric power supply sockets. Do so for all units and the controller.

Multiple Spectrals Pro Set Up

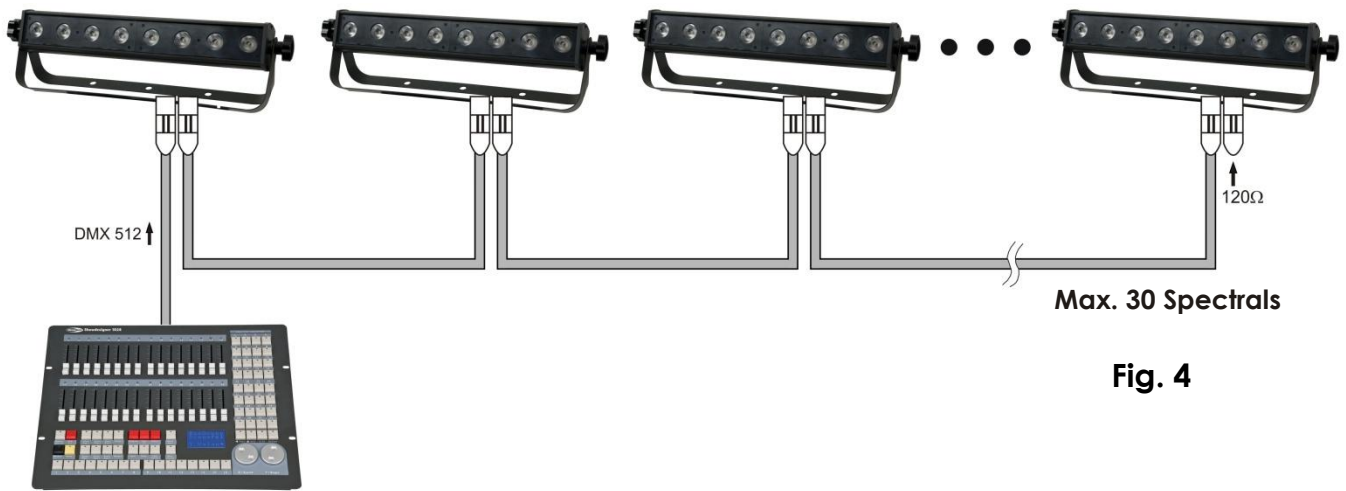

Fig. 4

Note : Link all DMX cables and set dip switches before connecting electric power

5. Do not supply power before the whole system is set up and connected properly. Design your show according to your DMX controller functions. See page 14 and 15 for more about DMX programming.

Fixture Linking

You will need a serial data link to run light shows of one or more fixtures using a DMX-512 controller or to run synchronized shows on two or more fixtures set to a master/slave operating mode. The combined number of channels required by all the fixtures on a serial data link determines the number of fixtures the data link can support.

The Spectral CYC650 uses a maximum of 24 channels.

Important: Fixtures on a serial data link must be daisy chained in one single line. To comply with the EIA-485 standard no more than 30 devices should be connected on one data link. Connecting more than 30 fixtures on one serial data link without the use of a DMX optically isolated splitter may result in deterioration of the digital DMX signal.



Maximum recommended DMX data link distance: 100 meters
Maximum recommended number of Spectrals on a DMX data link: 30 fixtures
@ 220V: 24 units may be connected in series
@ 120V: 12 units may be connected in series

Data Cabling

To link fixtures together you must obtain data cables. You can purchase DAP Audio certified DMX cables directly from a dealer/distributor or construct your own cable. If you choose to create your own cable please use data-grade cables that can carry a high quality signal and are less prone to electromagnetic interference.

DAP Audio Certified DMX Data Cables

- DAP Audio Basic microphone cable for allround use. bal. XLR/M 3 p. > XLR/F 3 p.
Ordercode FL01150 (1,5m.), FL013 (3m.), FL016 (6m.), FL0110 (10m.), FL0115 (15m.), FL0120 (20m.).
- DAP Audio cable for the demanding user with exceptional audio-qualities and connector made by Neutrik®. **Ordercode** FL71150 (1,5m.), FL713 (3m.), FL716 (6m.), FL7110 (10m.).



The Spectral CYC650 has a total of 4 DMX channel configurations, referred to as **Personalities**. The 5 personalities are [TOUR, PIXEL, ARC1, ARC1+D, HSV]. Each of the different personalities can be accessed from the control panel.

Control Panel

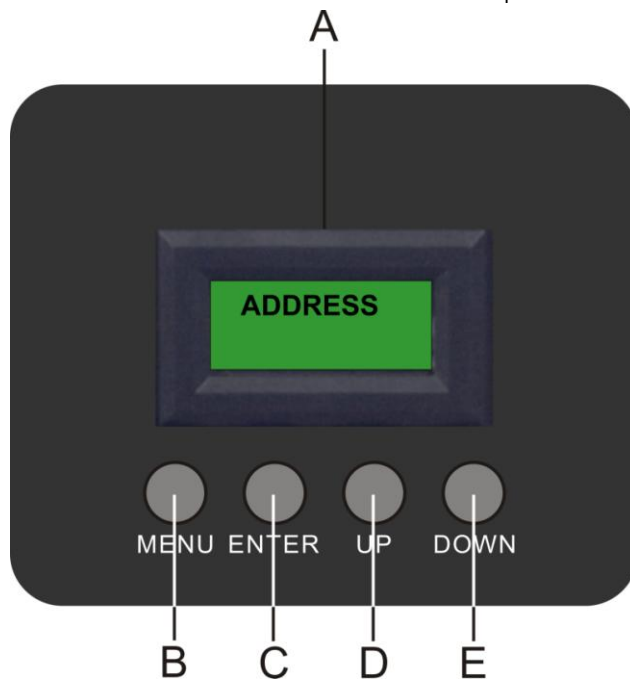

Fig. 5

- A. Display
- B. MENU Button
- C. ENTER Button
- D. Up Button
- E. Down Button

DMX Control Mode

The fixtures are individually addressed ADDRESS
[001-512] on a data-link and connected to the controller. The fixtures respond to the DMX signal from the controller. (When you select the DMX address and save it, the controller will display the saved DMX address the next time.)

DMX Addressing

The control panel on the front side of the base allows you to assign the DMX fixture address, which is the first channel from which the Spectral will respond to the controller.

Please note when you use the controller, the unit has max. **24** channels.

When using multiple Spectrals, make sure you set the DMX addresses right.

Therefore, the DMX address of the first Spectral should be **1(001)**; the DMX address of the second Spectral should be **1+24=25**; the DMX address of the third Spectral should be **25+24=49**, etc.

Please, be sure that you don't have any overlapping channels in order to control each Spectral correctly. If two or more Spectrals are addressed similarly, they will work similarly.

For address settings, please refer to the instructions under "Addressing".

Controlling:

After having addressed all Spectrals, you may now start operating these via your lighting controller.

Note: After switching on, the Spectral will automatically detect whether DMX 512 data is received or not. The problem may be:

- The XLR cable from the controller is not connected with the input of the Spectral.
- The controller is switched off or defective, the cable or connector is defective, or the signal wires are swapped in the input connector.

Note: It's necessary to insert a XLR termination plug (with 120 Ohm) in the last fixture in order to ensure proper transmission on the DMX data link.

The Spectral will only show its version number at start-up !



Main Menu Options

Press the MODE button to scroll through 11 options of the menu:

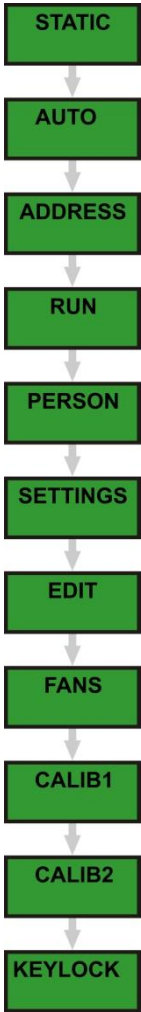

1. Creating a static color

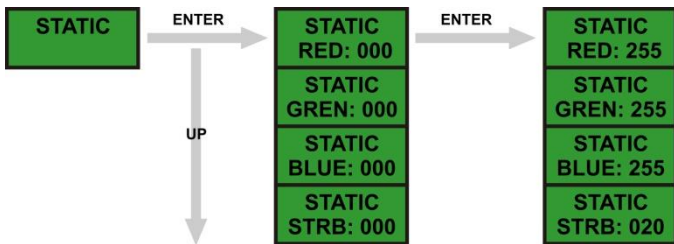

- 1) When you press ENTER in menu Static color, you have to use DOWN to scroll through this menu.
- 2) Use the UP/DOWN buttons to change the static colors (Red, Green, Blue) or the strobe speed (0-20Hz).
- 3) Press MENU to go 1 step back.
- 4) You can combine RED, GREEN and BLUE to create an infinite range of colors (0-255).

Red

Set the value of the red LEDs (0-255).

Strobe

Set the value of the flash (0-20Hz).

Green

Set the value of the green LEDs (0-255).

Blue

Set the value of the blue LEDs (0-255).

2. Activating an Auto Program

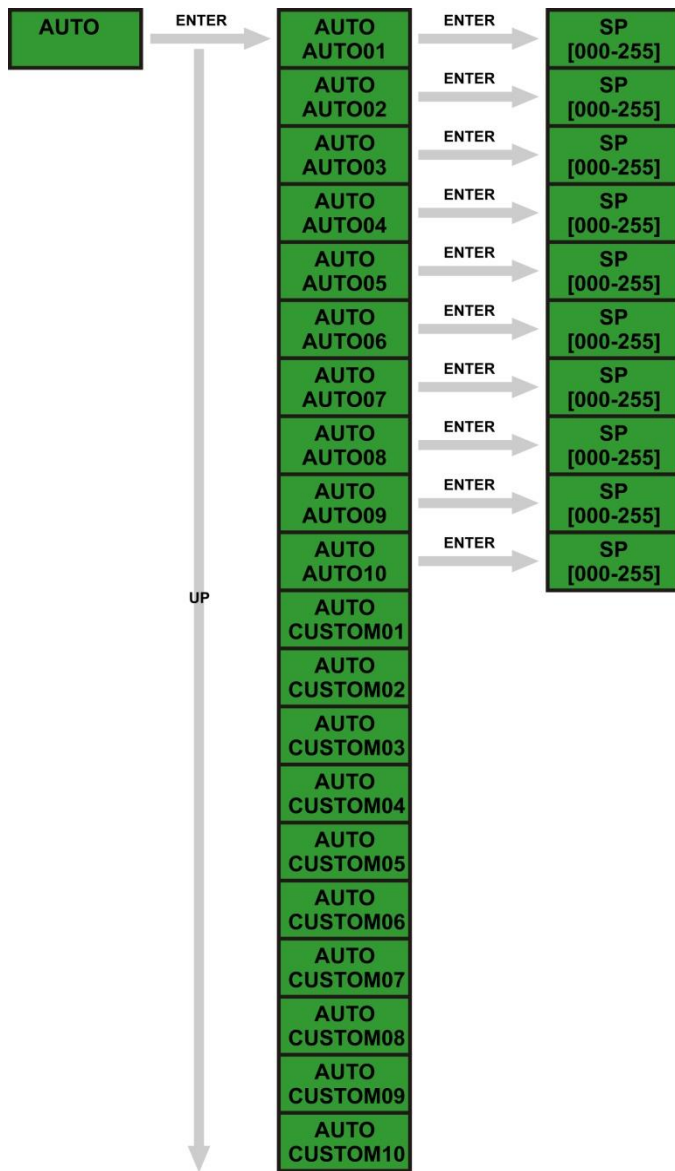

- 1) When you press ENTER in menu AUTO, you can choose one of the 10 built-in programs.
- 2) Press ENTER after selecting the desired auto program, You can select the auto speed of the 10 built-in programs from 000-255.
- 3) You can also edit 10 custom programs.

3. DMX 512 Address



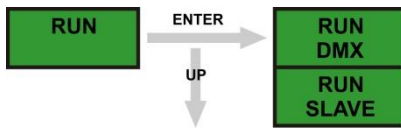

- 1) When you press ENTER in menu DMX 512 address you can set the DMX address.
- 2) You can choose your DMX address between 001-512.

4. Run Mode



1) Enter the RUN MODE mode to set the desired working mode:

- DMX mode is used when working with a DMX512 controller to control the Spectral.
- SLAVE mode is for using the device during a Master-Slave operation.

 When the fixtures are in Auto program operation, the RUN MODE does not work. 

5. Personality

Enter the PERSONALITY mode to select a DMX mode: TOUR, PIXEL, ARC1, ARC1+D, HSV.

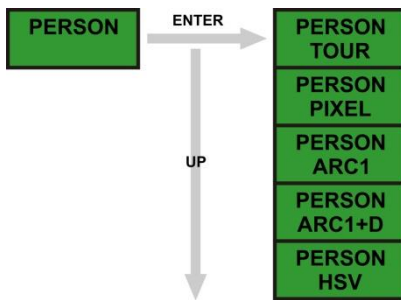

TOUR: 10 channels
PIXEL: 24 channels
ARC1: 3 channels
ARC1+D: 4 channels
HSV: 3 channels

6. Changing the Settings

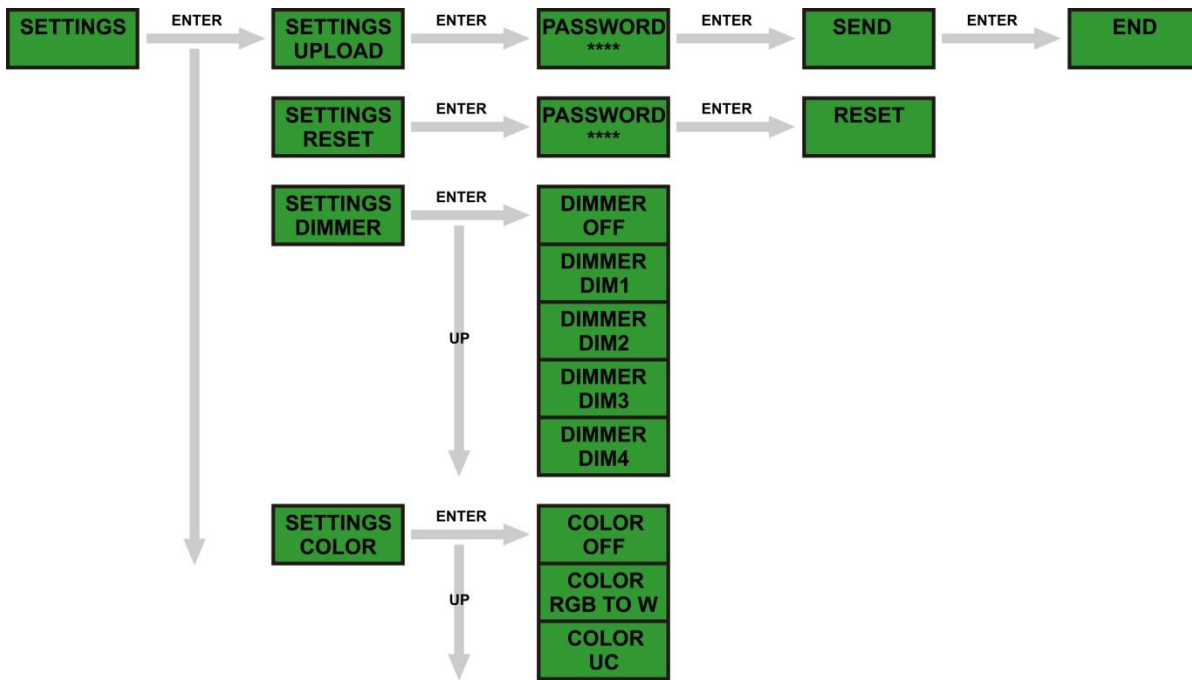

- 1) Enter UPLD to upload the custom programs from the current MASTER device to all SLAVE devices. In order to activate the upload function the password must be entered.

Password: UP > DOWN > UP > DOWN. Then press ENTER to confirm your password

When uploading the MASTER and SLAVE units will light up YELLOW.

If an error occurs when uploading the MASTER and/or SLAVE devices will light up RED.

When uploading one of the custom programs has been successful, the MASTER and SLAVE devices will light up GREEN

- 2) In order to reset the custom modes to its default values select REST.
- 3) Enter DIM Mode to select a certain dimmer mode and dimmer speed. When DIMMER is set to OFF, then RGBW and the MASTER DIMMER are linear. Dim 1/2/3/4 are speed modes of the non linear dimmer. DIM1 is fastest, and DIM4 is slowest. The DIM setting does not have any effect in TOUR mode. The DMX setting overrules the DIM setting.
- 4) The Color settings menu enables you to activate/deactivate the color calibration functions. When you have selected **RGBW** to ON, RGB TO WHITE has been set. This means RGB = 255, 255, 255. The color is displayed as you have calibrated the specific color in menu **CALIBRATION2 → RGBW**. When it is set to **NO**, on RGB = 255,255,255, the RGB values are not adjusted and the output is most powerful. The **RGB**'s parameter can be adjusted in **CALIBRATION2**.
- 5) When **UC** is selected, the RGB output is adjusted to a standard preset universal color. This way, different versions of Spectral CYC650's are color balanced to match each other.

7. FACTORY DEFAULT SETTINGS

1	STATIC = 000
2	DMX Address = 001
3	Run Mode = DMX
4	Personality = TOUR
5	DIMMER = DIM4
6	COLOR = OFF
7	EDIT = 000
8	FAN = AUTO
9	KEYLOCK = OFF

8. Edit Custom

With this menu you are able to create your own custom scenes.

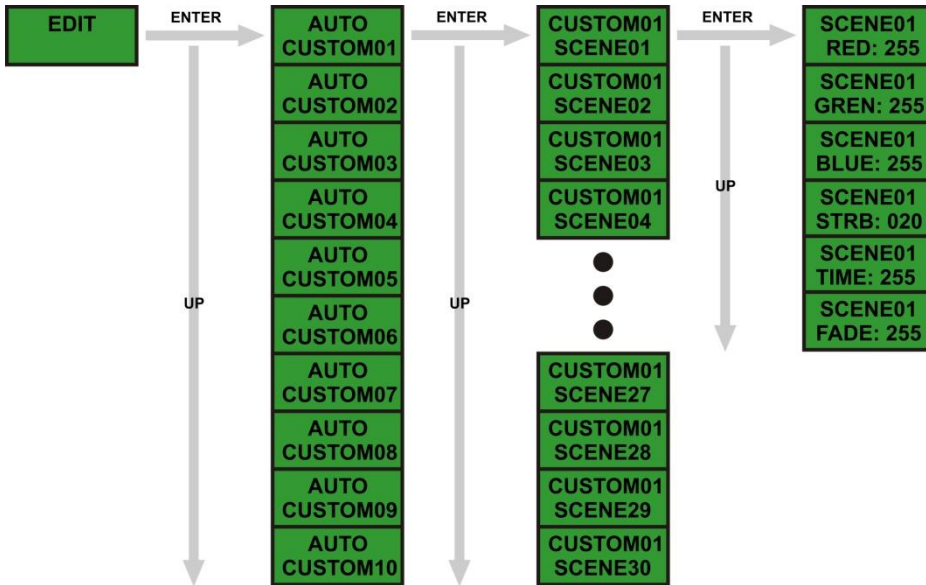

- 1) Enter the EDIT CUSTOM mode to edit the custom programs CUSTOM01 – CUSTOM10.
- 2) Each custom program has 30 steps, which can be edited.
- 3) Each step allows the creation of a scene using RED, GREEN, BLUE, STROBE, STEP TIME & FADE.

9. Fans

With this menu you are able to control the fan speed of the device.

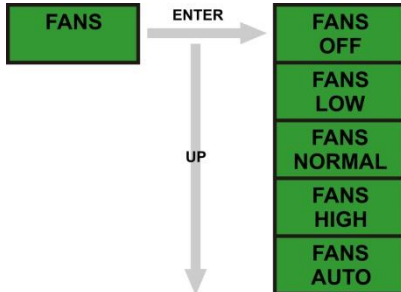

- 1) Press Menu, until the display shows: **FANS**
- 2) Press enter to open this menu. Scroll through the menu to set the desired fan speed.



IMPORTANT !



Do no use the FAN OFF option !!!

The device can become damaged and warranty will become void !!!

10. White Settings

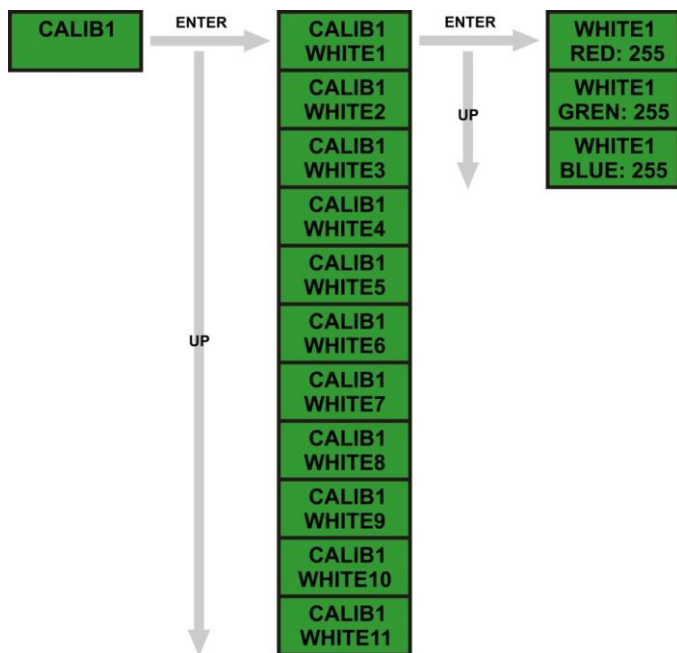

- 1) Enter **CALIB** menu to select the white colors of a certain color temperature.
- 2) There are 11 pre-programmed White colors that can be edited by using RED, GREEN and BLUE.

11. White Settings (RGB Recalibration)

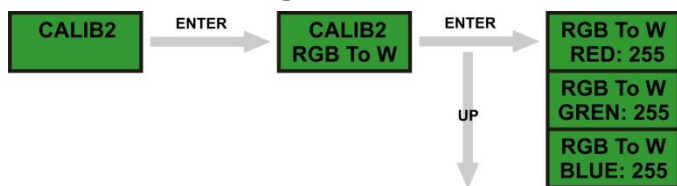

- 1) RGB TO WHITE can be edited by using RED, GREEN and BLUE.

12. Activate Password

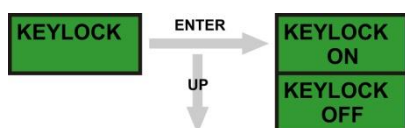

- 1) Enter the KEY-LOCK mode to select, whether the access password is On or Off.
- 2) The **Access Password: UP + DOWN + UP + DOWN**.
- 3) When you have pressed ENTER in menu KEY ON, it will take 30 seconds before the Spectral is locked.
- 4) When the password is activated, the display will ask for password each time the fixture is powered on.

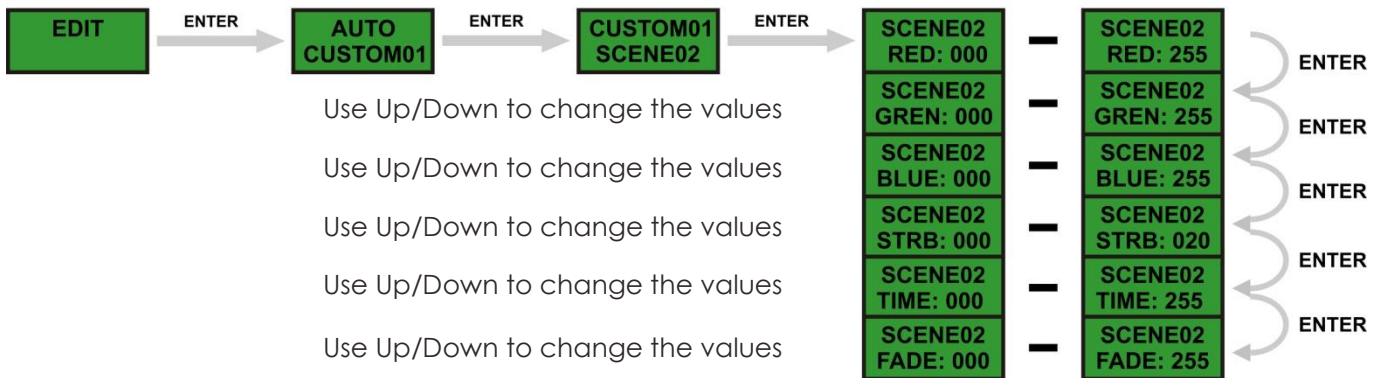
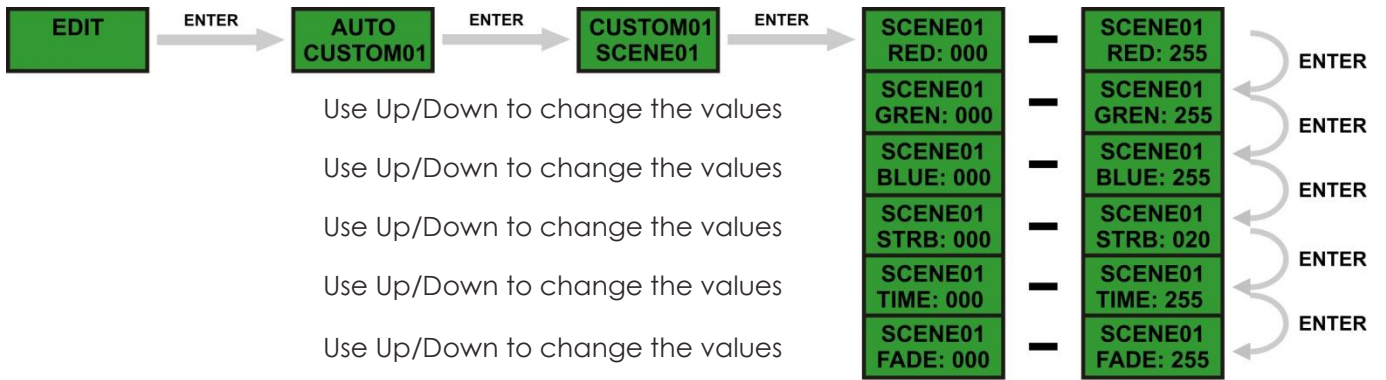

How to make your own Custom Program



- 1) And so you can add a maximum of 30 scenes.
- 2) After that you can start with **CUSTOM02** and create a maximum of 30 scenes again.
- 3) You can repeat these steps, until you've reached CUSTOM10, step 30.
- 4) This means, it is possible to create 300 separate scenes.

DMX MODES

10-Channel (TOUR)

Channel	Value	Function
1	000 – 255	Dimmer 0 – 100 %
2	000 – 255	Red 0 – 100 %; CH2 will control the STEP TIME , if CH7 is set to custom 01-10 (only if CH7 161-255)
3	000 – 255	Green 0 – 100 %; CH3 will control the FADE TIME , if CH7 is set to custom 01-10 (only if CH7 161-255)
4	000 – 255	Blue 0 – 100 %
5	000 – 010 011 – 030 031 – 050 051 – 070 071 – 090 091 – 110 111 – 130 131 – 150 151 – 170 171 – 200 201 – 205 206 – 210 211 – 215 216 – 220 221 – 225 226 – 230 231 – 235 236 – 240 241 – 245 246 – 250 251 – 255	Macro Colors No Function Red 100% / Green Up / Blue 0% Red Down / Green 100% / Blue 0% Red 0% / Green 100% / Blue Up Red 0% / Green Down / Blue 100% Red Up / Green 0% / Blue 100% Red 100% / Green 0% / Blue Down Red 100% / Green Up / Blue Up Red Down / Green Down / Blue 100% Red 100% / Green 100% / Blue 100% White 1: 3200K White 2: 3400K White 3: 4200K White 4: 4900K White 5: 5600K White 6: 5900K White 7: 6500K White 8: 7200K White 9: 8000K White 10: 8500K White 11: 10000K
6	000 – 009 010 – 255	Strobe No Function 0 – 20 Hz
7	000 – 010 011 – 020 021 – 030 031 – 040 041 – 060 061 – 070 071 – 080 081 – 090 091 – 100 101 – 110 111 – 120 121 – 130 131 – 140 141 – 150 151 – 160 161 – 170 171 – 180 181 – 190 191 – 200 201 – 210 211 – 220 221 – 230 231 – 240 241 – 250 251 – 255	Auto + Custom No Function Fans OFF (after 3 seconds)  Do no use the FAN OFF option !!!  Fans NORMAL (after 3 seconds) Fans HIGH (after 3 seconds) Fans AUTO (after 3 seconds) Auto 1 Auto 2 Auto 3 Auto 4 Auto 5 Auto 6 Auto 7 Auto 8 Auto 9 Auto 10 Custom 1 Custom 2 Custom 3 Custom 4 Custom 5 Custom 6 Custom 7 Custom 8 Custom 9 Custom 10
8	000 – 255	Auto Speed. CH8 will control the AutoSpeed , if CH7 is set to AUTO 1-AUTO 10 (only if CH7 061-160)

9	000 – 009	Dimmer Speed. Preset Dimmer Speed from Display Menu	
	010 – 029	Linear Dimmer	
	030 – 069	Non Linear Dimmer (fastest) 1	
	070 – 129	Non Linear Dimmer 2	
	130 – 189	Non Linear Dimmer 3	
	190 – 255	Non Linear Dimmer (slowest) 4	
10	000 – 019	Block Selections. Block 1 – 8	
	020 – 039	Block 1, Block 2	
	040 – 059	Block 3, Block 4	
	060 – 079	Block 5, Block 6	
	080 – 099	Block 7, Block 8	
	100 – 119	Block 1, Block 2, Block 3, Block 4	
	120 – 139	Block 1, Block 2, Block 5, Block 6	
	140 – 159	Block 1, Block 2, Block 7, Block 8	
	160 – 179	Block 3, Block 4, Block 5, Block 6	
	180 – 199	Block 3, Block 4, Block 7, Block 8	
	200 – 219	Block 5, Block 6, Block 7, Block 8	
	220 – 239	Blackout	
	240 – 255	Block 1 – 8	

MASTER DIMMER

- CH1 controls the intensity of the currently projected color.
- When the fader is at 255, the intensity of the output is at its maximum.

RED, GREEN & BLUE SELECTION

- Channels 2, 3 and 4 control the overall intensity of each respective color.
- Channels 2, 3 and 4 can be combined to create an unlimited range of colors.

COLOR MACROS & WHITE BALANCE

- Channel 5 selects the required COLOR MACRO and whites in different colors.
- Channel 5 has priority over channels 2, 3 and 4.
- Channel 1 is used to control the intensity of the COLOR MACRO.

STROBE

- CH6 is the strobe channel and controls the strobe effects of CH2, CH3, CH4 and CH5.
- The strobe is with an adjustable speed with a maximum of 20Hz.

AUTO

- Channel 7 selects the preset AUTO and CUSTOM programs (1-10).
- Channel 7 has priority over channels 2, 3, 4, 5 and 6.
- When activating the custom AUTO programs 1-10, it is possible to control the **Step Time (CH2)** and **Fade Time (CH3)**.

DIMMER SPEED

- Enter DIM Mode (CH9) to select specific dimmer mode and dimmer speed.
- When DIMMER is set to OFF, then RGBW and the MASTER DIMMER are linear. Dim 1/2/3/4 are speed modes of the non linear dimmer. DIM1 is fastest, and DIM4 is slowest.

BLOCK SELECTION

- CH10 allows the user to select a series of combinations of different colors and LED blocks.

24-Channel (PIXEL)

Channel	Value	Function
1	000 – 255	Block 1 Red 0 – 100 %
2	000 – 255	Block 1 Green 0 – 100 %
3	000 – 255	Block 1 Blue 0 – 100 %
4	000 – 255	Block 2 Red 0 – 100 %
5	000 – 255	Block 2 Green 0 – 100 %
6	000 – 255	Block 2 Blue 0 – 100 %
7	000 – 255	Block 3 Red 0 – 100 %
8	000 – 255	Block 3 Green 0 – 100 %
9	000 – 255	Block 3 Blue 0 – 100 %
10	000 – 255	Block 4 Red 0 – 100 %
11	000 – 255	Block 4 Green 0 – 100 %
12	000 – 255	Block 4 Blue 0 – 100 %
13	000 – 255	Block 5 Red 0 – 100 %
14	000 – 255	Block 5 Green 0 – 100 %
15	000 – 255	Block 5 Blue 0 – 100 %
16	000 – 255	Block 6 Red 0 – 100 %
17	000 – 255	Block 6 Green 0 – 100 %
18	000 – 255	Block 6 Blue 0 – 100 %
19	000 – 255	Block 7 Red 0 – 100 %
20	000 – 255	Block 7 Green 0 – 100 %
21	000 – 255	Block 7 Blue 0 – 100 %
22	000 – 255	Block 8 Red 0 – 100 %
23	000 – 255	Block 8 Green 0 – 100 %
24	000 – 255	Block 8 Blue 0 – 100 %

3-Channel (ARC1)

Channel	Value	Function
1	000 – 255	Red 0 – 100 %
2	000 – 255	Green 0 – 100 %
3	000 – 255	Blue 0 – 100 %

4-Channel (ARC1+D)

Channel	Value	Function
1	000 – 255	Master Dimmer 0 – 100 %
2	000 – 255	Red 0 – 100 %
3	000 – 255	Green 0 – 100 %
4	000 – 255	Blue 0 – 100 %

3-Channel (HSV)

Channel	Value	Function
1	000 – 255	Hue (Color variations) 0 – 100 %
2	000 – 255	Saturation of color Red 0 – 100 %
3	000 – 255	Value (Dimmer) 0 – 100 %

Beam Angles

RED

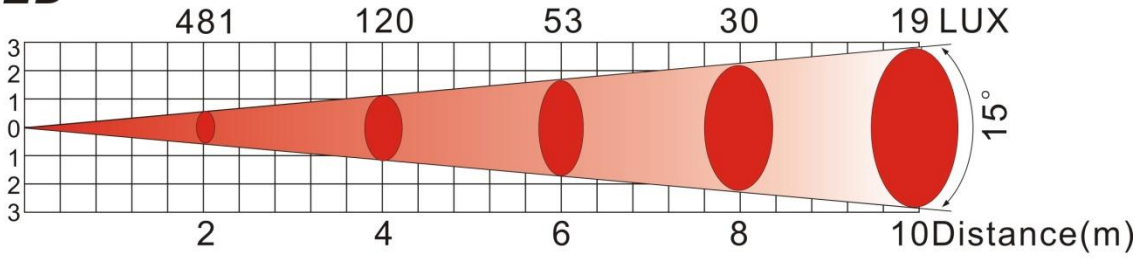

GREEN

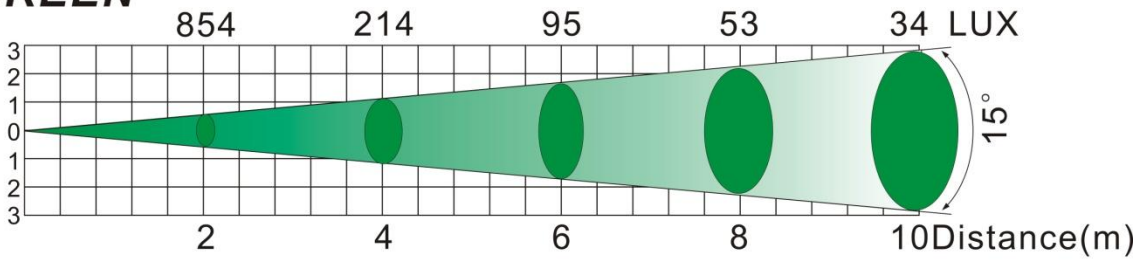

BLUE

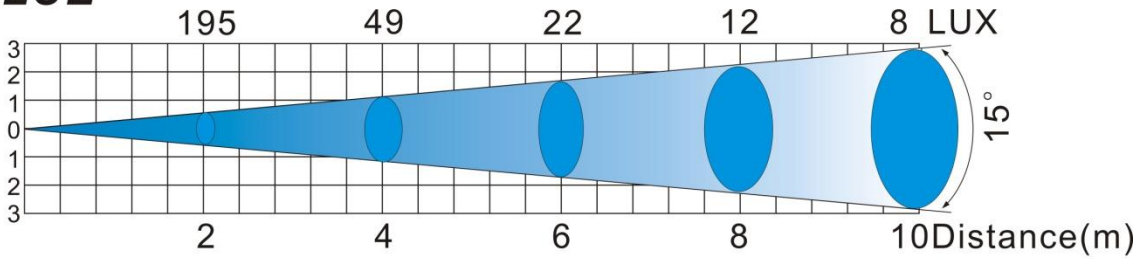

RGB

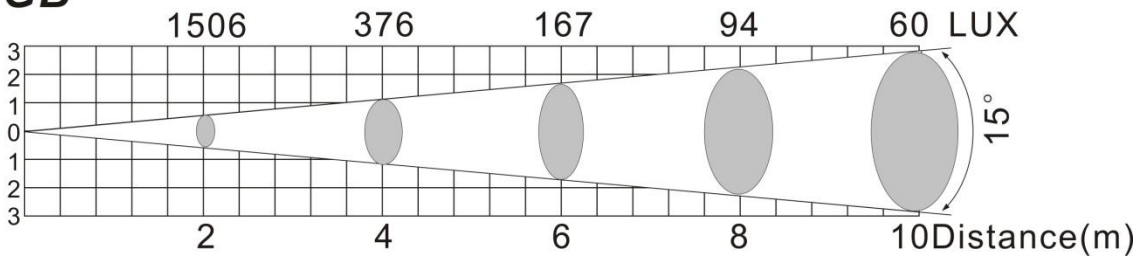

Connection Cables

Take care of the connector cables, always holding them by the connectors and avoiding knots and twists when coiling them: This gives the advantage of increasing their life and reliability, which is always to your advantage. Periodically check that your cables are in good condition, that they are correctly wired and that all their contacts are perfectly efficient: a great number of problems are caused entirely by using unsuitable or faulty cables.

Occupation of the XLR-connection:

DMX-OUTPUT XLR mounting-socket:



- 1 - Ground
- 2 - Signal (-)
- 3 - Signal (+)

DMX-input XLR mounting-plug

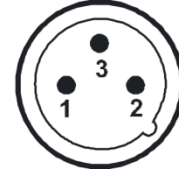

- 1 - Ground
- 2 - Signal (-)
- 3 - Signal (+)

The transformation of the controller line of 3 pins and 5 pins (plug and socket)

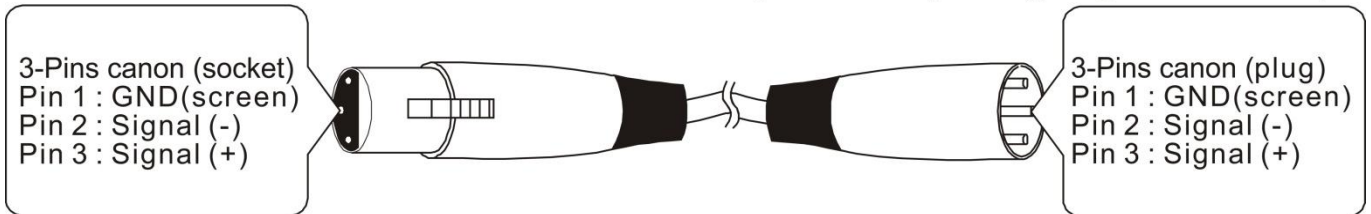

Maintenance

The Spectral CYC650 requires almost no maintenance. However, you should keep the unit clean. Otherwise, the fixture's light-output will be significantly reduced. Disconnect the mains power supply and then wipe the cover with a damp cloth. Wipe the front glass panel clean with glass cleaner and a soft cloth. Do not use alcohol or solvents. The front glass panel will require weekly cleaning, as smoke-fluid tends to build up residues, reducing the light-output very quickly. Do not immerse in liquid. Keep connections clean. Disconnect electric power, and then wipe the DMX connections with a damp cloth. Make sure connections are thoroughly dry before linking equipment or supplying electric power.

The operator has to make sure that safety-relating and machine-technical installations are to be inspected by an expert after every year in the course of an acceptance test.

The operator has to make sure that safety-relating and machine-technical installations are to be inspected by a skilled person once a year.

The following points have to be considered during the inspection:

1. All screws used for installing the device or parts of the device have to be tightly connected and must not be corroded.
2. There may not be any deformations on housings, fixations and installation spots.
3. Mechanically moving parts like axles, eyes and others may not show any traces of wearing.
4. The electric power supply cables must not show any damages or material fatigue.

Replacing a Fuse

Power surges, short-circuit or inappropriate electrical power supply may cause a fuse to burn out. If the fuse burns out, the product will not function whatsoever. If this happens, follow the directions below to do so.

1. Unplug the unit from electric power source.
2. Insert a screwdriver into the slot in the fuse cover. Gently pry up the fuse cover. The fuse will come out.
3. Remove the used fuse. If brown or unclear, it is burned out.
4. Insert the replacement fuse into the holder where the old fuse was. Reinsert the fuse cover. Be sure to use a fuse of the same type and specification. See the product specification label for details.

Troubleshooting

No Light

This troubleshooting guide is meant to help solve simple problems.

If a problem occurs, carry out the steps below in sequence until a solution is found. Once the unit operates properly, do not carry out following steps.

If the light effect does not operate properly, refer servicing to a technician.

Response: Suspect three potential problem areas: the power supply, the LED, the fuse.

1. Power supply. Check that the unit is plugged into an appropriate power supply.
2. The LEDs. Return the Spectral to your Showtec dealer.
3. The fuse. Replace the fuse. See page 25 for replacing the fuse.
4. If all of the above appears to be O.K., plug the unit in again.
5. If you are unable to determine the cause of the problem, do not open the Spectral, as this may damage the unit and the warranty will become void.
6. Return the device to your Showtec dealer.

No Response to DMX

Response: Suspect the DMX cable or connectors, a controller malfunction, a light effect DMX card malfunction.

1. Check the DMX cable: Unplug the unit; change the DMX cable; then reconnect to electrical power. Try your DMX control again.
2. Determine whether the controller or light effect is at fault. Does the controller operate properly with other DMX products ? If not, take the controller in for repair. If so, take the DMX cable and the light effect to a qualified technician.

See next page for more problem solving.

Problem	Probable cause(s)	Remedy
One or more fixtures are completely dead.	No power to the fixture	<ul style="list-style-type: none"> • Check that power is switched on and cables are plugged in.
	Primary fuse blown.	<ul style="list-style-type: none"> • Replace fuse.
Fixtures reset correctly, but all respond erratically or not at all to the controller.	The controller is not connected.	<ul style="list-style-type: none"> • Connect controller.
	3-pin XLR Out of the controller does not match XLR Out of the first fixture on the link (i.e. signal is reversed).	<ul style="list-style-type: none"> • Install a phase reversing cable between the controller and the first fixture on the link.
Fixtures reset correctly, but some respond erratically or not at all to the controller.	Poor data quality	<ul style="list-style-type: none"> • Check data quality. If much lower than 100 percent, the problem may be a bad data link connection, poor quality or broken cables, missing termination plug, or a defective fixture disturbing the link.
	Bad data link connection	<ul style="list-style-type: none"> • Inspect connections and cables. Correct poor connections. Repair or replace damaged cables.
	Data link not terminated with 120 Ohm termination plug.	<ul style="list-style-type: none"> • Insert termination plug in output jack of the last fixture on the link.
	Incorrect addressing of the fixtures.	<ul style="list-style-type: none"> • Check address setting.
	One of the fixtures is defective and disturbs data transmission on the link.	<ul style="list-style-type: none"> • Bypass one fixture at a time until normal operation is regained: unplug both connectors and connect them directly together. • Have the defective fixture serviced by a qualified technician.
	3-pin XLR Out on the fixtures does not match (pins 2 and 3 reversed).	<ul style="list-style-type: none"> • Install a phase-reversing cable between the fixtures or swap pin 2 and 3 in the fixture, that behaves erratically.
No light	Fixture is too hot.	<ul style="list-style-type: none"> • Allow fixture to cool. • Clean fan. • Make sure air vents at control panel and front lens are not blocked. • Turn up the air conditioning.
	LEDs damaged	<ul style="list-style-type: none"> • Disconnect fixture and return to your dealer.
	The power supply settings do not match local AC voltage and frequency.	<ul style="list-style-type: none"> • Disconnect fixture. Check settings and correct if necessary.

Product Specification

Power Supply: AC 100V-240V, 50/60 Hz

Combining the elements of smooth 3-in-1 LED color mixing with pixel animation effects.

Ideal tool for entertainment applications of any size

Suitable for use on floor to light up walls or decorations.

Spectral CYC650 able to be slotted end-to-end or side-by-side

Dim4 technology on board, which simulates the dimming curve of a halogen lamp

Programming of flowing chases is very easy.

LED Quantity: 8x 3-in-1 LED

3-pin DMX In and 3-pin DMX Out (XLR 3 Pin)

Neutrik Powercon Input and Output

Multivoltage (100-240V)

High light-output

Drive current: 350mA

Colour temperature presets (3,200 K ~ 10,000 K)

Control personality: TOUR, PIXEL, ARC1, ARC1+D, HSV

Peak Power 154 Watt; Continuous Power 82 Watt

On-board: Display for Auto and Custom control

Control protocol: DMX 512

Dimmer: 0-100%

Strobe: 0-20Hz

Cooling: Forced Cooling (Fan)

Overheat Protection

3, 3, 4, 10 or 24-channel LED wash light

4 different DMX Operating modes

Built-in automated programs via DMX

Recall custom programs via DMX

LED display with lock-out feature

Beam angle: 16°

Fan Speed Control

Max. Distance: 20m

Output: Lumen: 640+

Lux @ 2m: 1500+

Max. Distance: 20m

Double-bracket doubles as floor stand

Accessories: Included: Manual, safety cable, bracket

Housing: Black Extruded aluminium

Dimensions: 562 x 88 x 230 mm (LxWxH)

Weight: 3,54 kg

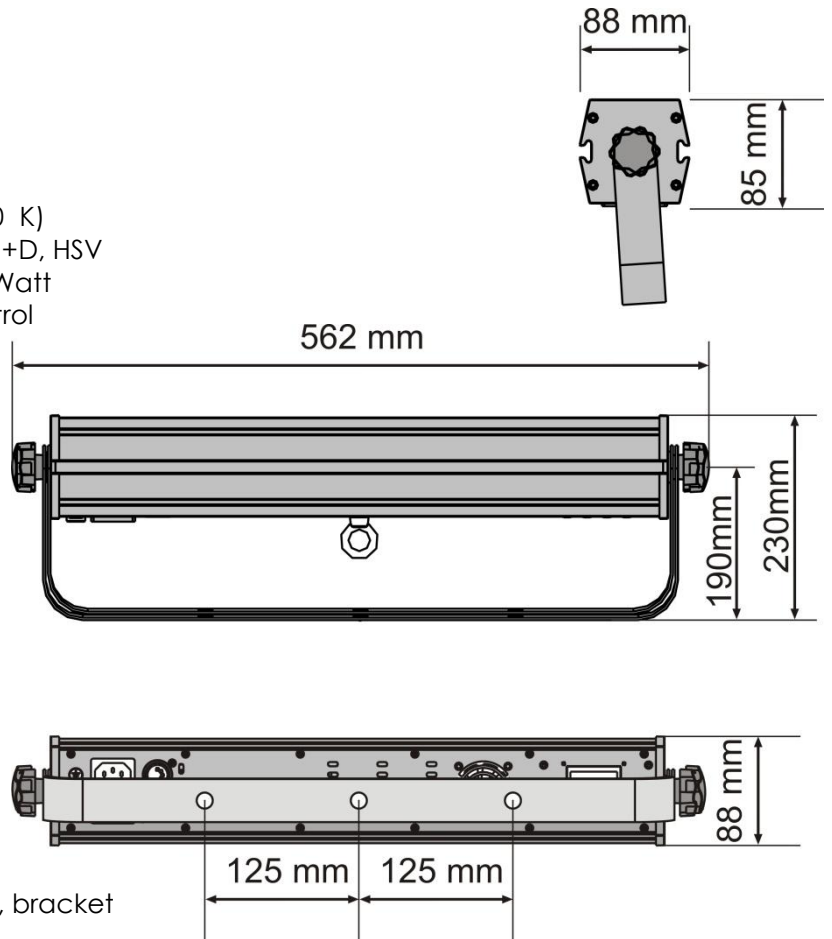

TOUR: 11 channels

PIXEL: 24 channels

ARC1: 3 channels

ARC1+D: 4 channels

HSV: 3 channels

Design and product specifications are subject to change without prior notice.



Website: www.Showtec.info

Email: service@highlite.nl



© 2012 Showtec.