



Explorer 250 Basic MKII

ORDERCODE 40176



SHOWELECTRONICS FOR PROFESSIONALS

Congratulations!

You have bought a great, innovative product from Showtec.

The Showtec Explorer brings excitement to any venue. Whether you want simple plug-&-play action or a sophisticated DMX show, this product provides the effect you need.

You can rely on Showtec, for more excellent lighting products.

We design and manufacture professional light equipment for the entertainment industry.

New products are being launched regularly. We work hard to keep you, our customer, satisfied.

For more information: iwant@showtec.info

You can get some of the best quality, best priced products on the market from Showtec.

So next time, turn to Showtec for more great lighting equipment.

Always get the best -- with Showtec !

Thank you!



Warning	2
Safety-instructions.....	2
Operating Determinations.....	3
Rigging.....	4
Description	5
Features and Overview	5
Backside.....	6
Installation	7
Installing the Lamp	7
Lamp Adjustment.....	8
Beam Angle	8
Set Up and Operation	9
One Explorer	9
Multiple Explorers.....	9
Master/Slave mode.....	10
DMX-Protocol	10
Control Panel.....	13
Control Mode.....	13
DMX addressing.....	13
Control panel functions.....	14
Menu Overview.....	15
Advanced Mode (14 Channels).....	16
Basic Mode (13 Channels).....	16
V. 2006 Mode (10 Channels).....	16
Channel settings.....	17
Maintenance	17
Changing the Lamp.....	18
Replacing the Fuse.....	18
Gobo Orientation.....	18
Replacing a Gobo from the Rotating Gobo-wheel	19
Structure of the Fixture.....	20
Electrical Diagram.....	21
Troubleshooting	22
No Light, No Movement - All Products.....	22
No Response to DMX	22
Product Specifications	24

WARNING



CAUTION!
Keep this device away from rain and moisture!
Unplug mains lead before opening the housing!



**FOR YOUR OWN SAFETY, PLEASE READ THIS USER MANUAL CAREFULLY
BEFORE YOUR INITIAL START-UP!**

SAFETY INSTRUCTIONS

Every person involved with the installation, operation and maintenance of this device has to:

- be qualified
- follow the instructions of this manual



CAUTION! Be careful with your operations.
With a dangerous voltage you can suffer
a dangerous electric shock when touching the wires!



Before your initial start-up, please make sure that there is no damage caused by transportation. Should there be any, consult your dealer and do not use the device.

To maintain perfect condition and to ensure a safe operation, it is absolutely necessary for the user to follow the safety instructions and warning notes written in this manual.

Please consider that damages caused by manual modifications to the device are not subject to warranty.

This device contains no user-serviceable parts. Refer servicing to qualified technicians only.

IMPORTANT:

The manufacturer will not accept liability for any resulting damages caused by the non-observance of this manual or any unauthorized modification to the device.

- Never let the power-cord come into contact with other cables! Handle the power-cord and all connections with the mains with particular caution!
- Never remove warning or informative labels from the unit.
- Never use anything to cover the ground contact.
- Never run the device without lamp!
- Never ignite the lamp if the objective-lens or any housing-cover is open, as discharge lamps may expose and emit a high ultraviolet radiation, which may cause burns.
- Never lift the fixture by holding it at the projector-head, as the mechanics may be damaged. Always hold the fixture at the transport handles.
- Never place any material over the lens.
- Never look directly into the light source.
- Never leave any cables lying around.
- Never unscrew the screws of the rotating gobo, as the ball bearing will otherwise be opened.
- Do not insert objects into air vents.
- Do not connect this device to a dimmerpack.
- Do not switch the device on and off in short intervals, as this would reduce the lamp's life.
- Do not touch the device's housing bare-handed during its operation (housing becomes very hot). Allow the fixture to cool for at least 5 minutes before handling.
- Do not shake the device. Avoid brute force when installing or operating the device.
- Only use device indoor, avoid contact with water or other liquids.
- Only operate the fixture after having checked that the housing is firmly closed and all screws are tightly fastened.
- Only operate the device after having familiarized with its functions.
- Avoid flames and do not put close to flammable liquids or gases.
- Always replace the lamp, when it is damaged or deformed due to the heat.
- Always keep case closed while operating.

- Always allow free air space of at least 50 cm around the unit for ventilation.
- Always disconnect power from the mains, when device is not used, before cleaning or when replacing lamp! Only handle the power-cord by the plug. Never pull out the plug by tugging the power-cord.
- To ensure the longest and most efficient use of the lamp always wait 15 minutes before re-applying power after a shutdown. Failure to do so could result in premature aging of the lamp and failure to the electronics that drive it.
- Make sure that the device is not exposed to extreme heat, moisture or dust.
- Make sure that the available voltage is not higher than stated on the rear panel.
- Make sure that the power-cord is never crimped or damaged. Check the device and the power-cord from time to time.
- If the lens is obviously damaged, it has to be replaced. So that its functions are not impaired, due to cracks or deep scratches.
- If device is dropped or struck, disconnect mains power supply immediately. Have a qualified engineer inspect for safety before operating.
- If the device has been exposed to drastic temperature fluctuation (e.g. after transportation), do not switch it on immediately. The arising condensation water might damage your device. Leave the device switched off until it has reached room temperature.
- If your Showtec device fails to work properly, discontinue use immediately. Pack the unit securely (preferably in the original packing material), and return it to your Showtec dealer for service.
- For adult use only. Movinghead must be installed out of the reach of children. Never leave the unit running unattended.
- Never attempt to bypass the thermostatic switch or fuses.
- For replacement use lamps and fuses of same type and rating only.
- Replace the lamp if it becomes defective or worn out, or before usage exceeds the maximum service life.
- Allow the fixture to cool down for 15 minutes, before opening the fixture and replacing lamp. Protect your hands and eyes with gloves and safety glasses.
- This device falls under protection class I. Therefore it is essential to connect the yellow/green conductor to earth.
- During the initial start-up some smoke or smell may arise. This is a normal process and does not necessarily mean that the device is defective.
- Repairs, servicing and electric connection must be carried out by a qualified technician.
- WARRANTY: Till one year after date of purchase.



OPERATING DETERMINATIONS

This device is not designed for permanent operation. Consistent operation breaks will ensure that the device will serve you for a long time without defects.

The minimum distance between light-output and the illuminated surface must be more than 1 meter.

The maximum ambient temperature t_a must never be exceeded.

If this device is operated in any other way, than the one described in this manual, the product may suffer damages and the warranty becomes void.

Any other operation may lead to dangers like short-circuit, burns, electric shock, lamp explosion, crash etc.

You endanger your own safety and the safety of others!

Rigging

Please follow the European and national guidelines concerning rigging, trussing and all other safety issues.

Do not attempt the installation yourself !

Always let the installation be carried out by an authorized dealer !

Procedure:

- If the projector is lowered from the ceiling or high joists, professional trussing systems have to be used.
- Use a clamp to mount the projector, with the mounting-bracket, to the trussing system.
- The projector must never be fixed swinging freely in the room.
- The installation must always be secured with a safety attachment, e.g. an appropriate safety net or safety-cable.
- When rigging, derigging or servicing the projector, always make sure, that the area below the installation place is blocked and staying in the area is forbidden.

The Explorer can be placed on a flat stage floor or mounted to any kind of truss by a clamp.

Mounting a clamp to the underside of the Explorer moving head

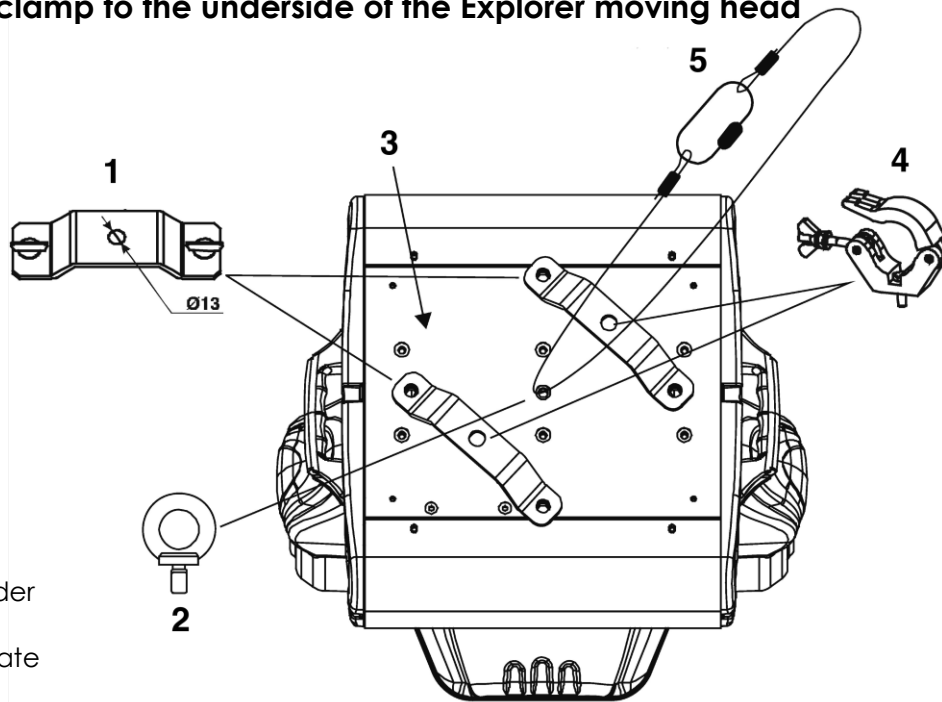

- 1) Omega Holder
- 2) Eye bolt
- 3) Mounting plate
- 4) Clamp
- 5) Safety-cable

Improper installation can cause serious damage to people and property !

Connection with the mains

Connect the device to the mains with the power-plug.

Always pay attention, that the right color cable is connected to the right place.

International	EU Cable	UK Cable	US Cable	Pin
L	BROWN	RED	YELLOW/COPPER	FASE
N	BLUE	BLACK	SILVER	NUL
	YELLOW/GREEN	GREEN	GREEN	EARTH

Make sure that the device is always connected properly to the earth!

Description of the device

Features

The Showtec Explorer is a moving head with high output and great effects.

- 1 Color-wheel with 7 colored gobos, and open
- 1 Gobo-wheel with 3 metal and 2 glass interchangeable rotating gobos plus open
- DMX-control via standard DMX-controller
- 14 DMX-control channels required
- Mechanical Dimmer/Shutter/Strobe
- Strobe-effect with adjustable speed (1 - 10 flashes/sec.)
- Sound-controlled via built-in microphone
- Linear electric focus
- Pan 0° -- 530°
- Tilt 0° -- 280°
- Pan/Tilt speed & reset control channel
- Automatic Pan/Tilt correction
- LED display menu with invert
- Pan/Tilt Invert option
- Micro-stepping motors
- Thermal switch
- Lamp MSD 250
- Fuse T3,15A / 250V

Overview



Fig. 1

- 1) Lens
- 2) Display + menu buttons

Backside



Fig. 2

- 3) DMX signal connector (OUT)
- 4) DMX signal connector (IN)
- 5) Power ON/OFF
- 6) IEC power connector + Fuse 3,15A 250V

Installation

Installing the Lamp

The Showtec Explorer uses the MSD 250 (ordercode 80920P / 80920O / 80933O / 82603 / 80935) reflectorbulb as manufactured by all popular manufacturers. Use only the appropriate lamp for your unit. Note that, product versions that use other lamps, may be offered in the future. Check your product specification label for information.

Always disconnect from electric mains power supply before changing lamps.

The lamp has to be replaced when it is damaged or deformed due to the heat.

Do not install lamps with a higher wattage! Lamps with a higher wattage generate temperatures the device was not designed for.

Damages caused by non-observance are not subject to warranty.

Procedure :

1. Loosen the 3 screws on the top cover and gently remove the small plastic housing.
2. Loosen the 2 screws on the small lamp cover and gently remove the lamp cover.
3. Read lamp instructions. Do not touch the lamp bulb glass.
Oil on hands shortens the lamp life. (If you touch the bulb glass, wipe off the glass with a clean, lint-free towel and rubbing alcohol.)
4. Insert the lamp pins into the small holes in the lamp socket. You can adjust the distance between the lamp and the lens on the back of the cover.
5. Put the lamp cover back and fasten the screws snugly. Then put the plastic housing back and fasten the screws snugly.

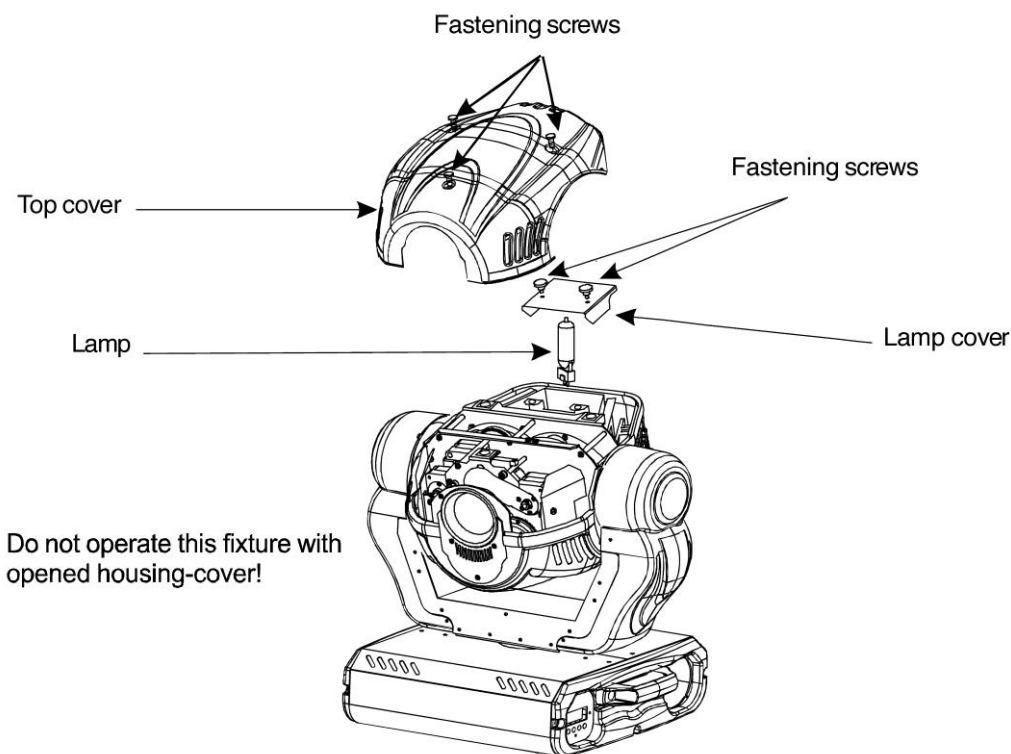

Fig. 3

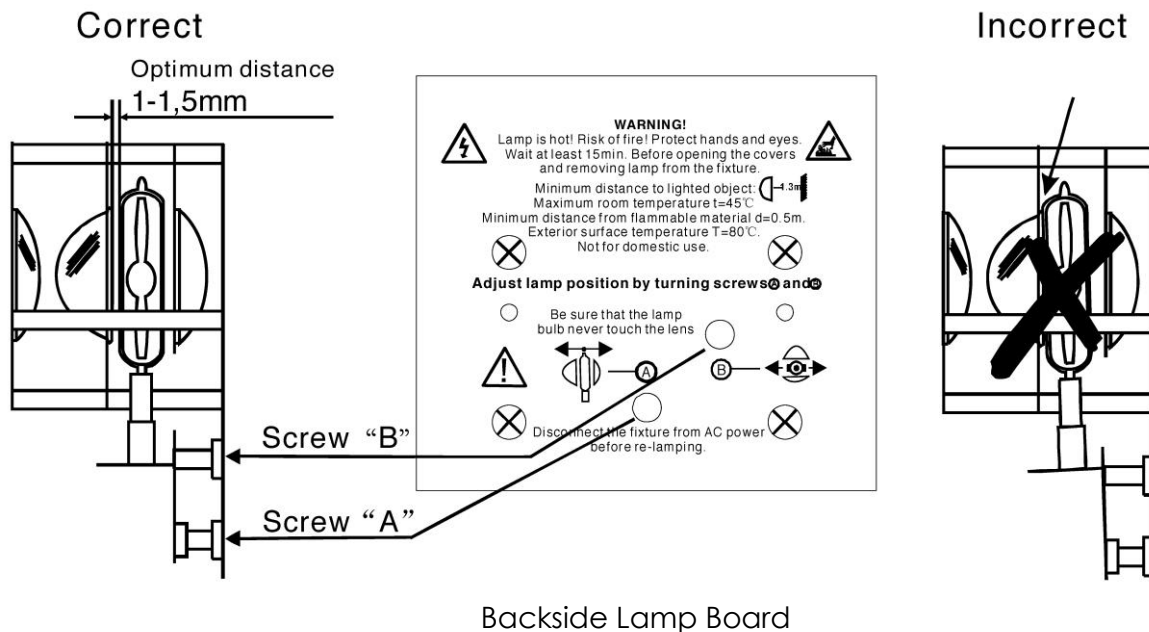

Fig. 4

Lamp Adjustment

You can adjust the lamp's position by turning the screws A, B.

The lamp position is set in the factory. As the lamps, which can be used, differ from manufacturer to manufacturer, it can be necessary to readjust the position. The lamp must be readjusted e.g., if the light does not seem to be evenly distributed within the ray of light.

Ignite the lamp and focus the ray of light on an even surface (wall). As the optimal distance between the lamp and the lens was already set during the installation with screw "A", only the "Hot Spot" (the brightest part of the ray of light) must be centered. Turn in addition screw "B". If the Hot Spot appears too bright, you can weaken its intensity, by moving the lamp closer to the reflector. Turn in addition screw "A", until the light is evenly distributed. If the light at the outside edge of the ray of light appears brighter as in the center, the lamp is too close to the reflector. In this case move the lamp away from the reflector, until the light is evenly distributed and the ray of light appears bright enough.

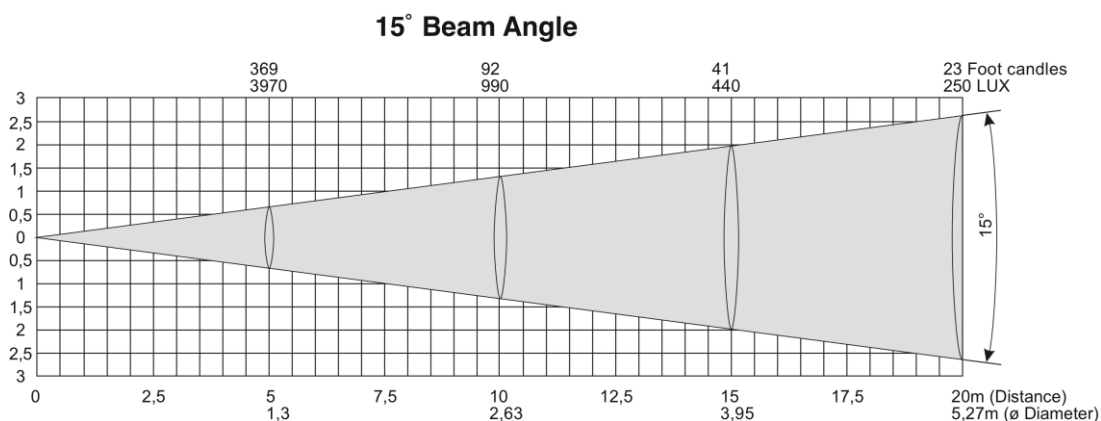

Set Up and Operation

Follow the directions below, as they pertain to your preferred operation mode. Before plugging the unit in, always make sure that the power supply matches the product specification voltage. Do not attempt to operate a 120V specification product on 230V power, or vice versa.

One Explorer

1. Fasten the moving head onto firm trussing (Use a clamp (ordercode 70351 / 70308 / 70322) fastened onto the Explorer). Leave at least 1 meter on all sides for air circulation.
2. Always use a safety cable (ordercode 70140 / 70141).
3. Plug one end of the electric mains power cord into the IEC socket on the unit. Then plug the other end of the cord into a proper electric power supply socket.
4. Use the Mode-button to set the fixture to Automatic Mode_1 or Automatic Mode_2. The Explorer will now play its built-in program.
5. Always use a safety cable (ordercode 70140 / 70141).

Multiple Explorers

1. Fasten the moving head onto firm trussing (Use a clamp (ordercode 70351 / 70308 / 70322) fastened onto the Explorer). Leave at least 1 meter on all sides for air circulation.
2. Always use a safety cable (ordercode 70140 / 70141).
3. Use a 3-p XLR cable to connect the Explorers and other devices.

Occupation of the XLR-connection:

DMX-OUTPUT XLR mounting-socket:



- 1 - Ground
- 2 - Signal (-)
- 3 - Signal (+)

DMX-input XLR mounting-plug

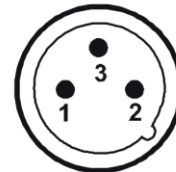

- 1 - Ground
- 2 - Signal (-)
- 3 - Signal (+)

The transformation of the controller line of 3 pins and 5 pins (plug and socket)

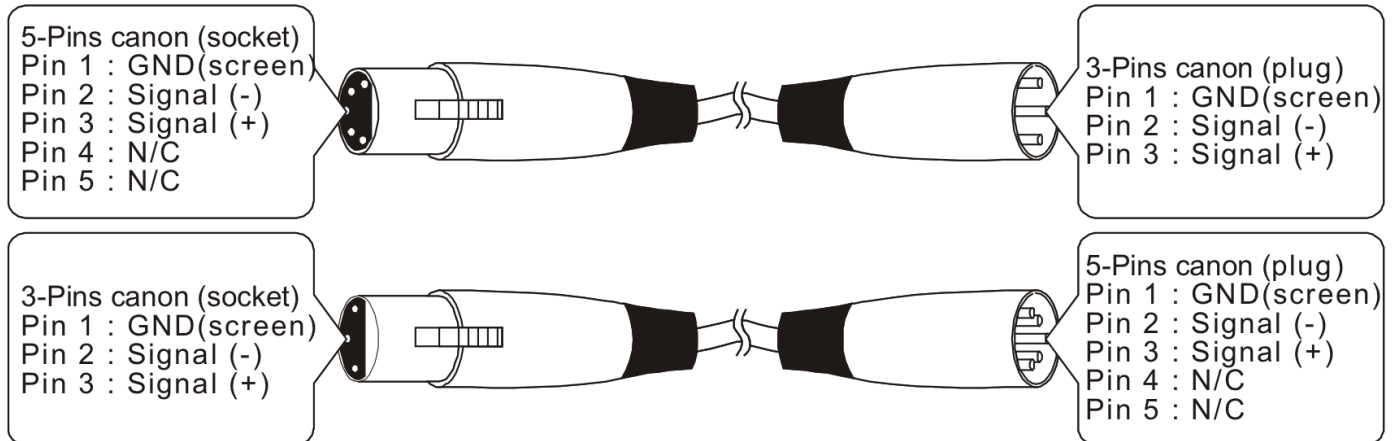

4. Link the units as shown in (figure 5), Connect a DMX signal cable from the first unit's DMX "out" socket to the second unit's "in" socket. Repeat this process to link the second, third, and fourth units.
5. Supply electric power: Plug electric mains power cords into each unit's IEC socket, then plug the other end of the mains power cord into proper electric power supply sockets, starting with the first unit. Do not supply power before the whole system is set up and connected properly.

Multiple Explorers Set Up



Fig. 5

Note : Link all cables before connecting electric power

DMX Protocol

Channel 1 - Horizontal movement (Pan)

Push the slider up, in order to move head horizontally (PAN).

Gradual head adjustment from one end of the slider to the other (0-255, 128-center).

The head can be turned by 530° and stopped at any position you wish.

Channel 2 - Vertical movement (Tilt)

Push the slider, up in order to move head vertically (TILT).

Gradual head adjustment from one end of the slider to the other (0-255, 128-center).

The head can be turned by 280° and stopped at any position you wish.

Channel 3 - Pan fine 16 bit

Channel 4 - Tilt fine 16 bit

Channel 5 – PAN/TILT Speed

0-255	From Max Speed (0) to Min. Speed (255) in vector mode
-------	---

Channel 6 – Lamp ON OFF & Reset

0-19	DMX 512
20-39	Automatic Mode 1
40-59	Automatic Mode 2
60-79	Music Mode 1 (No function)
80-99	Music Mode 2 (Reset)
100-119	Random
120-127	No Function
128-139	Lamp On/Off
140-229	No function
230-235	Lamp Off after 5 seconds
236-255	No function

Channel 7 – Colours

Linear color change following the movement of the slider. In this way you can stop the color-wheel in any position – also between two colors creating double-colored beams. Between 128 - 255, the color-wheel rotates continuously the so-called “Rainbow” effect.

0-15	Open / White
16-31	Red
32-47	Yellow
48-63	Magenta
64-79	Green
80-95	Orange
96-111	Blue
112-127	Pink
128-255	Forwards rainbow effect from fast to slow

Channel 8 – Prism

0-4	No rotation
5-127	Backwards rotation from fast to slow
128-132	No rotation
133-249	Forwards rotation from slow to fast
250-255	Lambency

Channel 9 – Rotating Gobo's

0-31	Open / White
32-47	Gobo 1 (glass)
48-63	Shaking Gobo 1
64-79	Gobo 2 (metal)
80-95	Shaking Gobo 2
96-111	Gobo 3 (glass)
112-127	Shaking Gobo 3
128-143	Gobo 4 (metal)
144-159	Shaking Gobo 4
160-175	Gobo 5 (metal)
176-191	Shaking Gobo 5
192-228	Open / White
229-255	Continuous Rotation from slow to fast

Channel 10 – Rotating gobo index, rotating gobo rotation

0-60	Gobo indexing
61-158	Forwards gobo rotation from fast to slow
159-255	Backwards gobo rotation from slow to fast

Channel 11 – Focus

0-255	From far distance to close distance
-------	-------------------------------------

Channel 12 – Shutter / Strobe

0-31	Shutter closed / Blackout
32-63	Shutter open
64-95	Strobe effect, from slow to fast (0-10 flashes/sec.)
96-127	Shutter open
128-159	Pulse-effect 1, in sequences from slow to fast
160-191	Shutter open
192-223	Random strobe effect, from slow to fast
224-255	Shutter open

Channel 13 – Dimmer intensity

0-255	From black to brightest
-------	-------------------------

Channel 14 – Effect

0-9	No Effect
10-19	Effect 1
20-29	Effect 2
30-39	Effect 3
40-49	Effect 4
50-59	Effect 5
60-69	Effect 6
70-79	Effect 7
80-89	Effect 8
90-99	Effect 9
100-109	Effect 10
110-119	Effect 11
120-129	Effect 12
130-139	Effect 13
140-149	Effect 14
150-159	Effect 15
160-169	Effect 16
170-179	Effect 17
180-189	Effect 18
190-199	Effect 19
200-209	Effect 20
210-219	Effect 21
220-229	Effect 22
230-239	Effect 23
240-249	Effect 24
250-255	Effect 25

The Explorer can be operated with a controller in **control mode** or without the controller in **stand-alone mode**.

Control Panel

When the indicator light is on, means the Explorer is working.

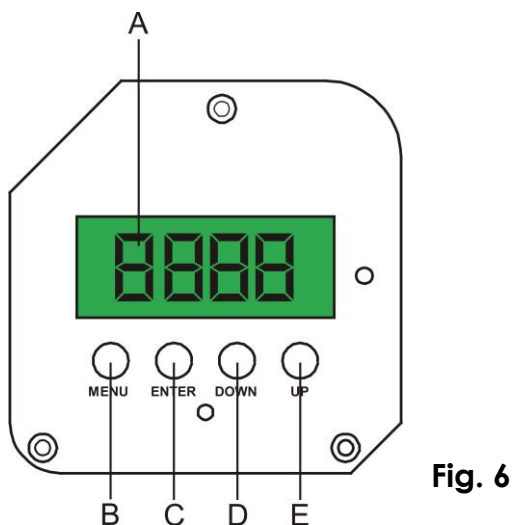

- | | |
|------------------|-------------------|
| A. LED | D. [ENTER] Button |
| B. Display | E. Up Button |
| C. [MODE] Button | F. Down Button |

Control Mode

The fixtures are individually addressed **A001 - A511** on a data-link and connected to the controller. The fixtures respond to the DMX signal from the controller. (When you select the DMX address and save it, the controller will display the saved DMX address the next time.)

DMX Addressing

The control panel on the front side of the base allows you to assign the DMX fixture address, which is the first channel from which the Explorer will respond to the controller.

Please note when you use the controller, the unit has **14** channels.

When using multiple Explorers, make sure you set the DMX addresses right.

Therefore, the DMX address of the first Explorer should be **1(A001)**; the DMX address of the second Explorer should be **1+14=15 (A015)**; the DMX address of the third Explorer should be **15+14=29 (A029)**, etc. Please, be sure that you don't have any overlapping channels in order to control each Explorer correctly.

If two or more Explorers are addressed similarly, they will work similarly.

For address settings, please refer to the instructions under "Addressing" (menu **A001**)

Controlling:

After having addressed all Explorer fixtures, you may now start operating these via your lighting controller.

Note: After switching on, the Explorer will automatically detect whether DMX 512 data is received or not.

If there is no data received at the DMX-input, the "LED " on the control panel will not flash.

The problem may be:

- The XLR cable from the controller is not connected with the input of the Explorer.
- The controller is switched off or defective, the cable or connector is defective, or the signal wires are swapped in the input connector.

Note: It's necessary to insert a XLR termination plug (with 120 Ohm) in the last fixture in order to ensure proper transmission on the DMX data link.

Remotely controllable functions

Colour-wheel

The Explorer contains a colour-wheel with 7 colours and one white. It is also possible to rotate the colour-wheel continuously at different speeds.

Rotating gobo-wheel

This rotating gobo-wheel has 3 metal gobos, 2 glass gobos and open.

Shutter/Dimmer/Strobe

The dimming (0-100%) is provided by a simple mechanical shutter unit. This unit may also be used for strobe effect (1-10 flashes per second).

Control Panel Functions

Stand-alone Mode

The fixture can execute 2 pre-set programs.

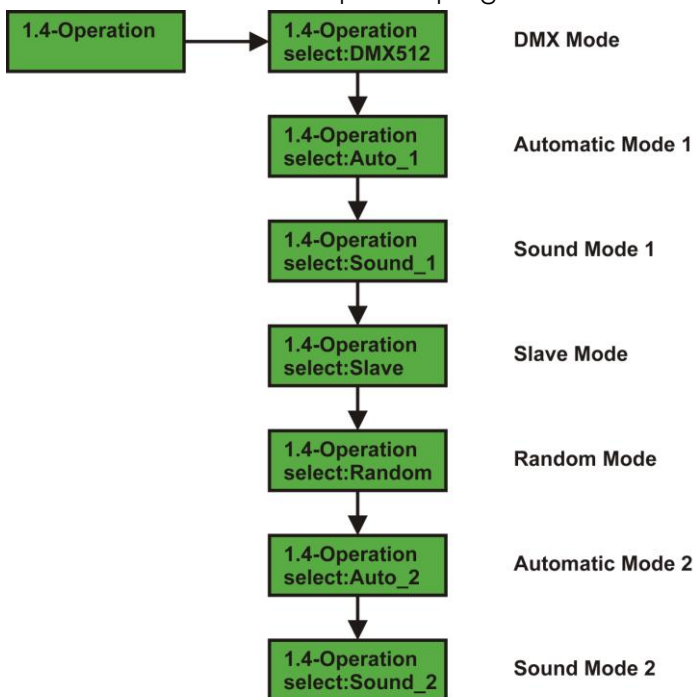

Use the MENU button to set the fixture to Auto_1, or Auto_2. The Explorer will now play its built-in program.

For synchronous operation of multiple fixtures the fixtures must all be connected on a data-link.

Note: Disconnect the fixtures from the DMX controller before operating, otherwise data collisions can occur and the fixtures will not work properly!

It's necessary to insert the XLR termination plug (with 120 Ohm) into the input of the first fixture and into the output of the last fixture in the data-link, in order to ensure proper transmission on the data link.

Addressing

With this menu you can set the DMX address or address a fixture as a master/slave.

001 - DMX addressing

- 1) Press MENU until the display shows 1.1-address, then press ENTER. The display will now show 001.
- 2) And press ▲ and ▼ to select the required address 001 – 512, press ENTER to confirm.
- 3) Press MENU, the chosen address is shown on the display.

Menu Overview

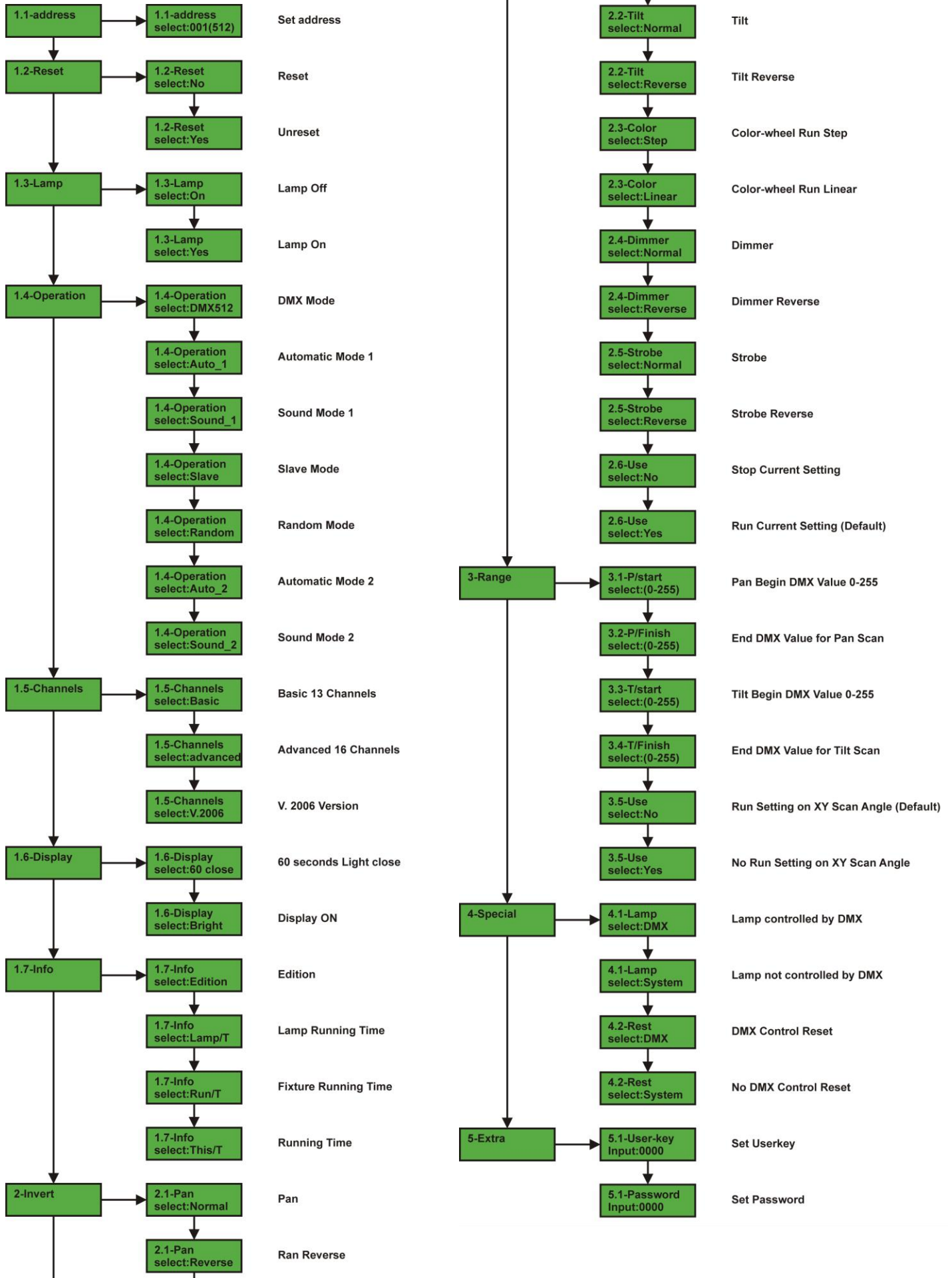

Advanced DMX Mode (14 Channels)

Channel	Function
1	Horizontal movement (Pan)
2	Vertical movement (Tilt)
3	Pan fine 16 bit
4	Tilt fine 16 bit
5	Scan Speed Adjustment
6	Lamp ON OFF & Reset
7	Static Color-wheel
8	Prism + Lambency
9	Rotating Gobo-wheel + Gobo Shake
10	Gobo-wheel rotation
11	Focus
12	Shutter / Strobe
13	Dimmer intensity
14	Effect

Basic DMX Mode (13 Channels)

Channel	Function
1	Horizontal movement (Pan)
2	Vertical movement (Tilt)
3	Pan fine 16 bit
4	Tilt fine 16 bit
5	Scan Speed Adjustment
6	Lamp ON OFF & Reset
7	Static Color-wheel
8	Prism + Lambency
9	Rotating Gobo-wheel + Gobo Shake
10	Gobo-wheel rotation
11	Focus
12	Shutter / Strobe
13	Dimmer intensity

V. 2006 DMX Mode (10 Channels)

Channel	Function
1	Horizontal movement (Pan)
2	Vertical movement (Tilt)
3	Lamp ON OFF & Reset
4	Static Color-wheel
5	Prism + Lambency
6	Rotating Gobo-wheel + Gobo Shake
7	Gobo-wheel rotation
8	Focus
9	Shutter / Strobe
10	Dimmer intensity

Channels settings

40176 Explorer 250-Basic MKII Rotating Gobo MSD-250 Fixture-settings														
Channel	1	2	3	4	5	6	7	8	9	10	11	12	13	14
Function	Pan	Tilt	Pan Fine	Tilt Fine	Speed	Lamp	Color	Rotating Prisma	Rotating Gobos	Gobo Rotation	Focus	Shutter Strobe	Dimmer	Effect
255	Clockwise 530° rotate 570	255	Clockwise 530° rotate	255	255 Slow	255 No Function 236 Lamp Off after 5 seconds 235 229 No Function 140 139 Lamp On/Off 128 127 No Function 120 119 Random 100 99 Music Mode 2 90 79 Music Mode 1 60 59 Automatic Mode 2 40 39 Automatic Mode 1 20 19 DMX 0	255 Fast Rainbow forward rotation 112 - 127 Pink 96 - 111 Blue 80 - 95 Orange 64 - 79 Green 48 - 63 Magenta 32 - 47 Yellow 16 - 31 Red 0 - 15 Open	255 Lambency 249 High Speed 133 Low Speed 133 128 127 High Speed 127 Backwards 5 Low Speed 4 0 No Rotation	229 - 255 Continuous Rotation from slow to fast 192 - 228 No Gobo 176 - 191 Gobo shake 160 - 175 Gobo 144 - 159 Gobo shake 128 - 143 Gobo 112 - 127 Gobo shake 96 - 111 Gobo 80 - 95 Gobo shake 64 - 79 Gobo 48 - 63 Gobo shake 32 - 47 Gobo 0 - 31 Open	255 Fast Backward Gobo-Rotation 159 Slow 158 Fast Forward Gobo-Rotation 61 Slow 60 Gobo-indexing 0-540° 0	255 Near Far	255 Shutter open 224 223 Fast Random Strobe 192 Slow 191 Fast Shutter open 180 Slow 159 Fast Pulse Effect 128 Slow 127 Shutter open 96 95 Fast Strobe Effect max. 10 Flash 64 Slow 63 Shutter open 32 31 Shutter closed 0	255 - 100%	250-255 Effect 25 240-249 Effect 24 230-239 Effect 23 220-229 Effect 22 210-219 Effect 21 200-209 Effect 20 190-199 Effect 19 180-189 Effect 18 170-179 Effect 17 160-169 Effect 16 150-159 Effect 15 140-149 Effect 14 130-139 Effect 13 120-129 Effect 12 110-119 Effect 11 100-109 Effect 10 90-99 Effect 9 80-89 Effect 8 70-79 Effect 7 60-69 Effect 6 50-59 Effect 5 40-49 Effect 4 30-39 Effect 3 20-29 Effect 2 10-19 Effect 1 0-9 No Effect

Maintenance

The operator has to make sure that safety-relating and machine-technical installations are to be inspected by an expert after every year in the course of an acceptance test.

The operator has to make sure that safety-relating and machine-technical installations are to be inspected by a skilled person once a year.

The following points have to be considered during the inspection:

1. All screws used for installing the device or parts of the device have to be tightly connected and must not be corroded.
2. There may not be any deformations on housings, fixations and installation spots.
3. Mechanically moving parts like axles, eyes and others may not show any traces of wearing.
4. The electric power supply cables must not show any damages or material fatigue.

The Showtec Explorer requires almost no maintenance. However, you should keep the unit clean. Otherwise, the fixture's light-output will be significantly reduced. Disconnect the mains power supply, and then wipe the cover with a damp cloth. Do not immerse in liquid. Wipe lens clean with glass cleaner and a soft cloth. Do not use alcohol or solvents.

The front lens will require weekly cleaning, as smoke-fluid tends to build up residues, reducing the light-output very quickly.

The cooling-fans, colour-filters, the gobowheel, the gobos and the internal lenses should be cleaned monthly with a soft brush.

Please clean internal components once a year with a light brush and vacuum cleaner.

Keep connections clean. Disconnect electric power, and then wipe the DMX and audio connections with a damp cloth. Make sure connections are thoroughly dry before linking equipment or supplying electric power.

Changing the Lamp

1. Loosen the 3 screws on the top cover and gently remove the small plastic housing.
2. Loosen the 2 screws on the small lamp cover and gently remove the lamp cover.
3. Follow directions for installing a new lamp, page 7.

Replacing a Fuse

Power surges, short-circuit or inappropriate electrical power supply may cause a fuse to burn out. If the fuse burns out, the product will not function whatsoever. If this happens, follow the directions below to do so.

1. Unplug the unit from electric power source.
2. Insert a screwdriver into the slot in the fuse cover. Turn the screwdriver to the left, at the same time gently push a bit (Turn and Push). The fuse will come out.
3. Remove the used fuse. If brown or unclear, it is burned out.
4. Insert the replacement fuse into the holder where the old fuse was. Reinsert the fuse cover. Be sure to use a fuse of the same type and specification. See the product specification label for details.

Gobo Orientation

Coated glass gobos are inserted with the coating against the rim of the holder (away from the spring). Textured gobos are inserted with the smooth side against the spring. This provides the best results when combining rotating gobos.

Coated side

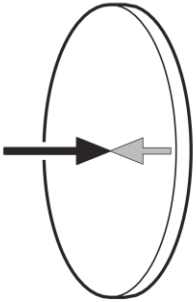

When an object is held up to the coated side there is no space between the object and its reflection. The back edge of the gobo cannot be seen when looking through the coated side.

Uncoated side

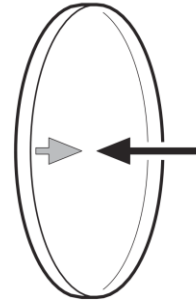

When an object is held up to the uncoated side there is a space between the object and its reflection. The back edge of the gobo can be seen when looking through the uncoated side.

Replacing a Gobo from the Rotating Gobo-wheel

Gobo-wheel with rotating gobo's

1. Disconnect mains power supply and set the switch to OFF.
2. Make sure that the gobo you want to insert has the same size (outer diameter is 37mm and the inner diameter is 29mm).
3. Turn the gobo wheel, with the gobo you want to remove, to the upside.
4. Very carefully take the pinchcock (fig 7 and 8) out of the gobo wheel, but pay attention that the pinchcock does not fall in the device. Then push the gobo out.
5. Place the new gobo in the gobo wheel. Carefully put the pinchcock back, gently press the pinchcock a little bit together. Possibly use a pair of pliers to press the pinchcock a little bit together.
6. Replace the maintenance cap and fasten all screws.

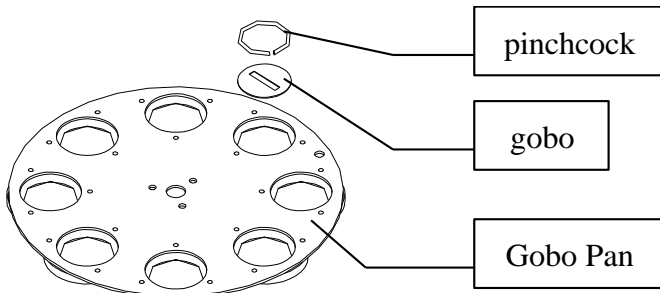

Fig. 7

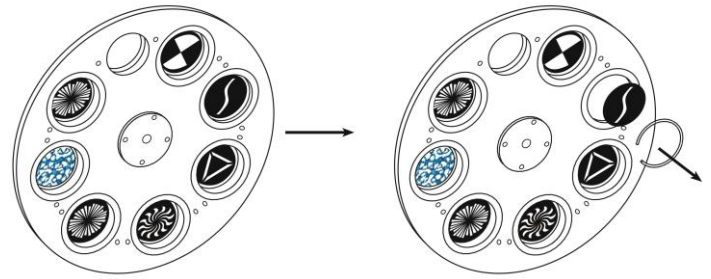

Fig. 8

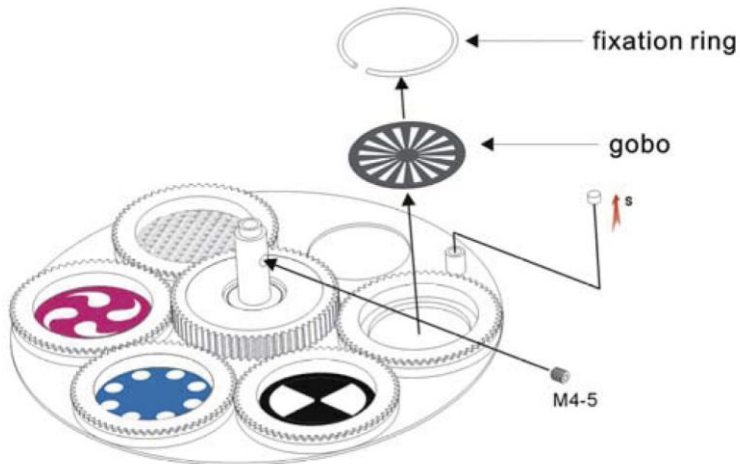
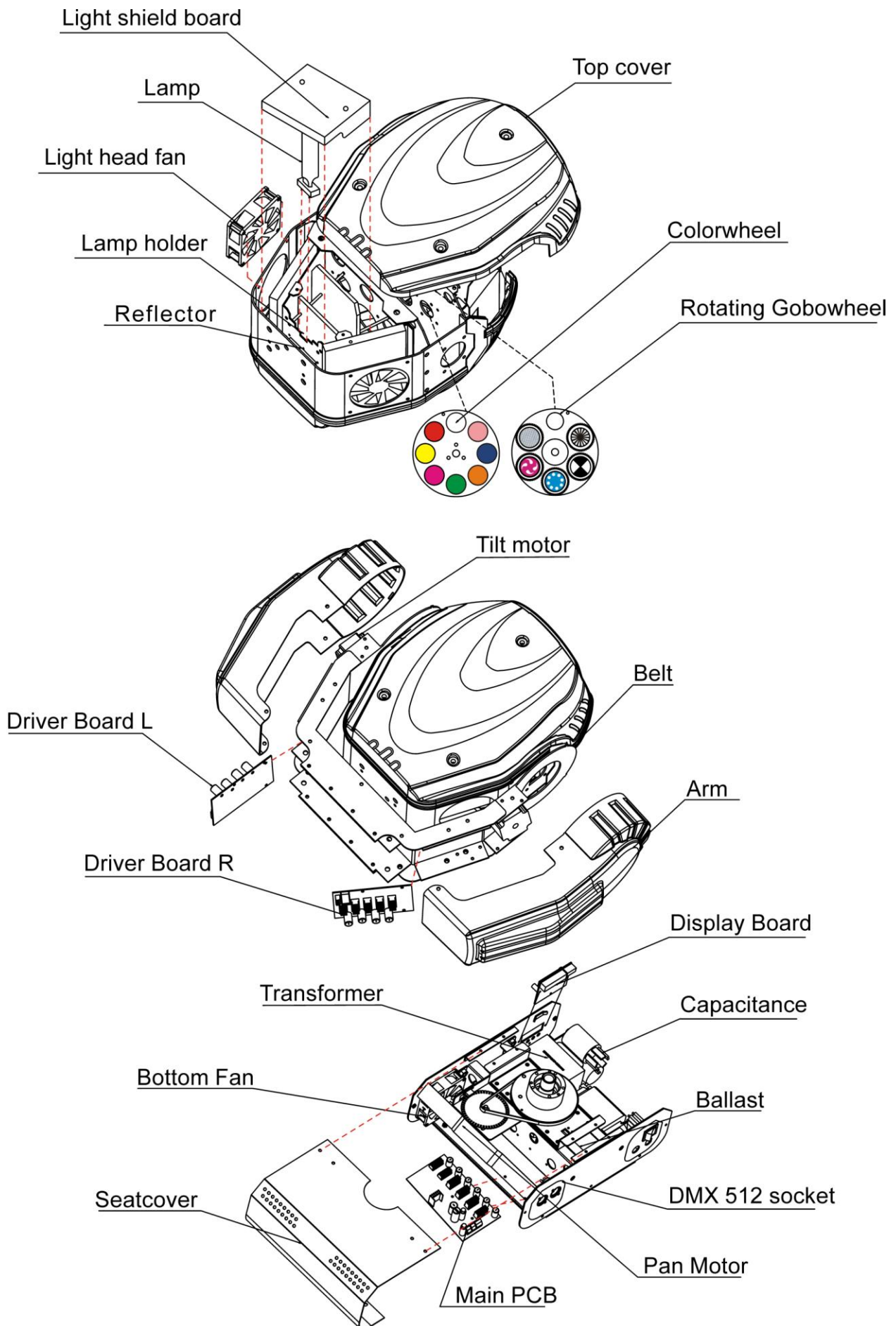
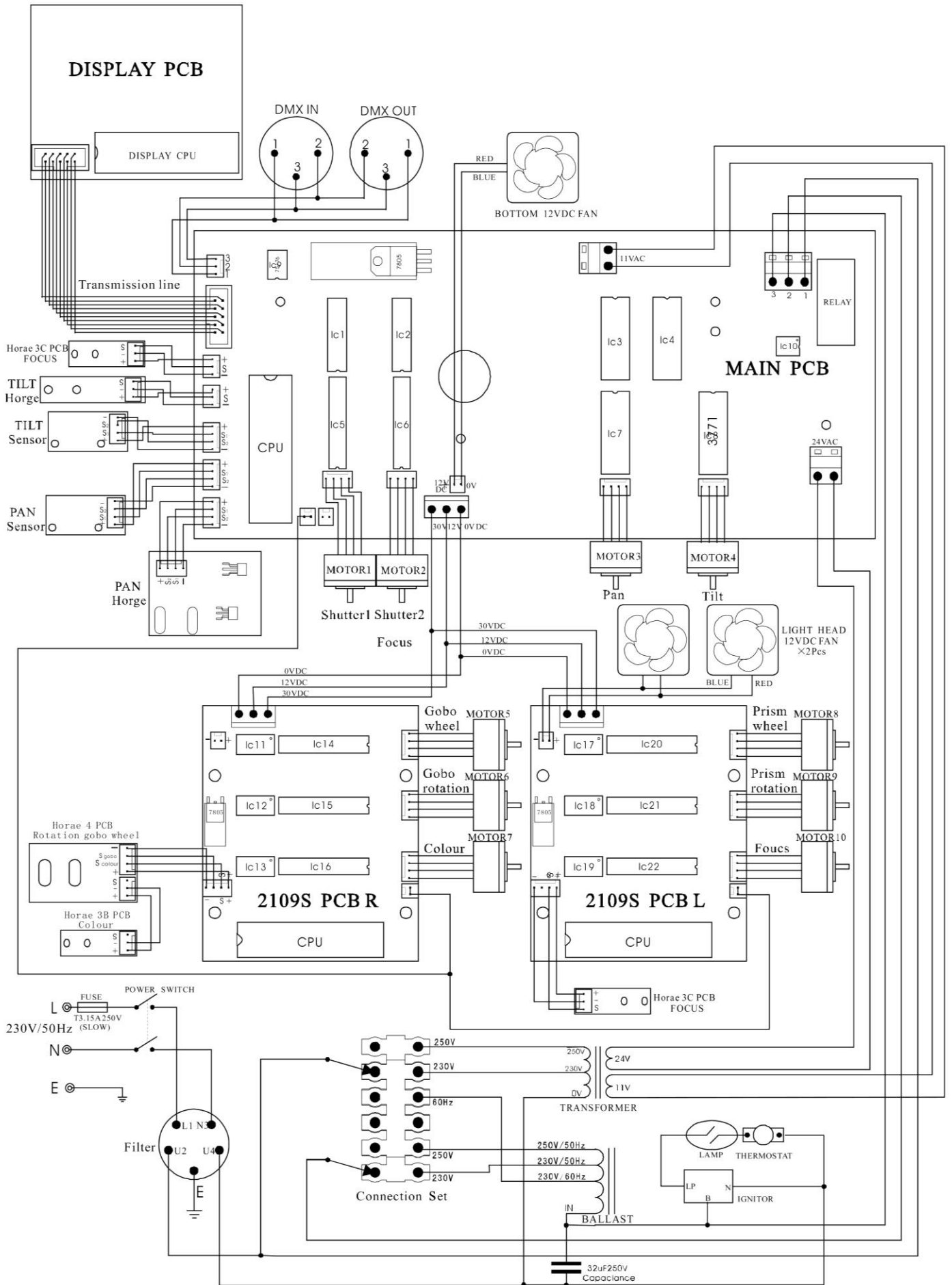

Fig. 9

Structure of the Fixture



Electrical Diagram



Troubleshooting

No Light, No Movement - All Products

This troubleshooting guide is meant to help solve simple problems. If a problem occurs, carry out the steps below in sequence until a solution is found. Once the unit operates properly, do not carry out following steps.

If the light effect does not operate properly, refer servicing to a technician.

Response: Suspect three potential problem areas: the power supply, the lamp, the fuse.

1. Power supply. Check that the unit is plugged into an appropriate power supply.
2. The lamp. Replace the old lamp with a new one with the same specifications. See page 7 for replacing lamps.
3. The fuse. Replace the fuse. See page 18 for replacing the fuse.

No Response to DMX

Response: Suspect the DMX cable or connectors, a controller malfunction, a light effect DMX card malfunction.

1. Check the DMX cable: Unplug the unit; change the DMX cable; then reconnect to electrical power. Try your DMX control again.
2. Determine whether the controller or light effect is at fault. Does the controller operate properly with Other DMX products ? If not, take the controller in for repair. If so, take the DMX cable and the light effect to a qualified technician.

See next page for more problem solving.

Problem	Probable cause(s)	Remedy
One or more fixtures are completely dead.	No power to the fixture	· Check that power is switched on and cables are plugged in.
	Primary fuse blown.	· Replace fuse.
Fixtures reset correctly, but all respond erratically or not at all to the controller.	The controller is not connected.	· Connect controller.
	3-pin XLR Out of the controller does not match XLR Out of the first fixture on the link (i.e. signal is reversed).	· Install a phase reversing cable between the controller and the first fixture on the link.
Fixtures reset correctly, but some respond erratically or not at all to the controller.	Poor data quality	· Check data quality. If much lower than 100 percent, the problem may be a bad data link connection, poor quality or broken cables, missing termination plug, or a defective fixture disturbing the link.
	Bad data link connection	· Inspect connections and cables. Correct poor connections. Repair or replace damaged cables.
	Data link not terminated with 120 Ohm termination plug.	· Insert termination plug in output jack of the last fixture on the link.
	Incorrect addressing of the fixtures.	· Check address setting.
	One of the fixtures is defective and disturbs data transmission on the link.	· Bypass one fixture at a time until normal operation is regained: unplug both connectors and connect them directly together. · Have the defective fixture serviced by a qualified technician.
	3-pin XLR Out on the fixtures does not match (pins 2 and 3 reversed).	· Install a phase-reversing cable between the fixtures or swap pin 2 and 3 in the fixture, that behaves erratically.
Shutter closes suddenly	The color wheel, gobo wheel, or a gobo has lost its index position and the fixture is resetting the effect.	· Contact a technician for servicing if the problem persists.
No light	The power supply settings do not match local AC voltage and frequency.	· Disconnect fixture. Check settings and correct if necessary.
	Lamp missing or blown	· Disconnect fixture and replace lamp.
Lamp cuts out intermittently.	Fixture is too hot.	· Allow fixture to cool. · Clean fan. · Make sure air vents at control panel and front lens are not blocked. · Turn up the air conditioning.
	The power supply settings do not match local AC voltage and frequency.	· Disconnect fixture. Check settings and correct if necessary.

Product Specification

Model: Showtec Explorer Basic
Voltage: 240V-50Hz (CE)
Fuse: 3,15A / 250V
Dimensions: 380x350x470mm (LxWxH)
Weight: 27,1 kg

Operation and Programming

Signal pin OUT: pin 1 earth, pin 2 (-), pin 3 (+)
Set Up and Addressing: LED control panel
DMX Channels: 14
Signal input 3-pin XLR male
Signal output 3-pin XLR female

Lamp

Allowed lamp models*:
Showtec NSD 250/2 (2000 hr) (ordercode 82603)
Philips MSD 250 (3000 hr; 6700K) ordercode 80920P
Osram HSD 250 (2000 hr; 6000K) ordercode 80926O
Sylvania 250 (3500 hr; 8500K) ordercode 80926S
Osram HSD 250/78 (1000 hr; 7800K) (ordercode 80933O)
Osram HSD 250/80 (1000 hr; 8000K) (ordercode 80935)
Control: Automatic and DMX remote ON / OFF

Electro-mechanical effects

Colors: 7 colors plus white
Gobos rotating: 3 rotating metal gobos, 2 rotating glass gobos and open
Colour-wheel with variable rotation speed
Gobo rotation: adjustable speed,
All lenses are anti-reflection coated
High luminous-efficiency parabolic system
Strobe-effect with variable speed (1 flash -- 10 flashes/sec.)
DMX-control via standard DMX-controller
Sound-controlled via built-in microphone
Pan 0° -- 530°
Tilt 0° -- 280°
Automatic Pan / Tilt position correction

Gobos

Glass gobo: heat-resistant and intensify glass; dichroic glass coating
Max. ambient temperature t_a : 40°C; Max. housing temperature t_B : 80°C
Outer diameter: 37mm
Inner diameter: 29mm
Cooling: 3 axial fans - two fan in the projector and one in the base
Motor: high quality stepping-motor controlled by microprocessors

Minimum distance:

Minimum distance from flammable surfaces: 0.5m
Minimum distance to lighted object: 2m

*: Versions for other lamps may be produced. Please check the specification label on your product.

Design and product specifications are subject to change without prior notice.



Website: www.Showtec.info
Email: service@highlite.nl



© 2008 Showtec.